

STUDENT NAME _____

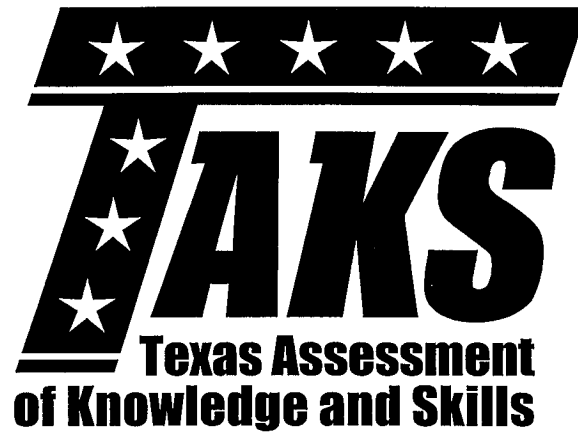

**EXIT LEVEL
ENGLISH LANGUAGE ARTS
MATHEMATICS
SCIENCE
SOCIAL STUDIES**

Administered July 2006

**READING
AND
WRITTEN
COMPOSITION**

DIRECTIONS

Read the two selections and the viewing and representing piece. Then answer the questions that follow.

In Search of Eels

from *The Tie That Binds*

by *Elisavietta Ritchie*

1 "Hi, Daddy, let's take a walk."

My notes about what I am
reading

2 It's a June day in Virginia. My father puts his hands on the arms of his wheelchair, whispers something I can't understand. I try to help him up but he is limp, resistant, heavy.

3 "Come for a walk, Daddy. Please."

4 The breeze billows white curtains into the room. The lawns have just been mowed and the fragrance of grass wafts inside.

5 He shivers, murmurs something about blizzards. Then, slightly more audibly, "It's cold, I'm tired. Can't we go home now?"

* * *

6 Suddenly we're far beyond Lake Shore Drive, in a part of the waterfront I've never seen before. December, Chicago, I'm five, and cold. One mitten's lost. My feet are tired. His legs are longer, he walks too quickly through yellowing snow, gritty slush, toward buildings like airplane hangars with cavernous mouths. Menacing.

7 He begins to tell me about ships and cargoes.

8 Usually I love to listen to his stories; he knows about everything in the world. But I've had enough walking. "I want to go home."

9 "Just as far as that warehouse." He strides on. "Right foot, left foot, you'll see—we could hike around the whole of Lake Michigan. Come on, hold my hand—*Forward, march!*"

10 "I don't want to hike around Lake Michigan."

11 But we reach the warehouse, shed he calls it, though it is 100 times bigger than any shed in anyone's backyard. By the pier beyond are big boats: tugs and freighters and tankers and tramps. Huge anchors. I keep hoping someone will drop them with a splash into the water. But the ships are docked with thick hawsers, nooses to choke the pilings. Funnels and cranes. Crates taller than my father sit on the wharves. Sunday and no one is working.

- 12 Suddenly the nearest freighter bellows from her funnel and I jump. From excitement, I insist, not fear.
- 13 This is the most exciting place I have ever been. I could walk along here forever. At least until I find out how to get aboard one of the boats.
- 14 Smaller sheds now, smaller boats, a green diner. Odor of fish, and smoke. We enter a shack. Barrels of brine, string bags of clams, crates of fish laid out on ice, their eyes terribly wide.
- 15 "Daddy, look at that snake!"
- 16 "No, that's an eel," says Daddy. "Smoked. We'll take a chunk home for supper."
- 17 "I certainly won't eat that!"
- 18 "All right," he says, and carries the smelly package. As we walk back, he tells me about migrations of eels to the Sargasso Sea: how eels come down Dalmatian rivers and swim across the Mediterranean and then the whole Atlantic, and eels come from the rivers of North America, too, until they reach the warm Sargasso Sea. Here they spawn, though I'm not quite sure what spawn means. Then the baby elvers swim back to the native rivers of their parent eels. My father explains that spawn is the proper word for something my grandmothers say people aren't supposed to discuss. But about eels, that's okay.
- 19 "Someday I will take one of these big ships. No," I correct myself, "a real ship with sails—and steer it to the Sargasso Sea."
- 20 He warns me that in the Sargasso Sea, the rudder, or the propeller screw, might get stuck in seines of floating algae. I'd never get home again.
- 21 Home is already far, Lake Michigan is too large, and although he sings old army marching songs to urge me to pick up my steps, toward the end of the journey he lets me ride home on his shoulders.
- 22 Back at last in the apartment, he unwraps the eel, opens his Swiss Army penknife (though he could have used the big kitchen knife) and slices carefully.
- 23 "I won't eat it," I say firmly.
- 24 "Try one bit, just for me."
- 25 "I won't like it."

- 26 While he hangs up our coats, finally I test one crumb.
Awfully smelly, smokey, and salty.
- 27 He goes into the kitchen to heat milk for my cocoa, and
tea for himself in the samovar from Tula. I test one more
sliver. Then another.
- 28 He returns with the steaming cups. The eel is gone.
- 29 Because it is Sunday and I am five, he forgives me.

* * *

- 30 Later, I am seven, or twelve, or fifteen. We are walking
along the canal, or a river, or best of all, a beach. I mostly
keep up. No eels now, but we see frogs and ducks, water
snakes, minnows. He tells me about everything in the
world. We talk about fishing.
- 31 Sometimes at the ocean we cast from a rock or pier or
the beach, though it is always the wrong bait or wrong tide.
Or we drop handlines over the side of somebody's boat. On
rare occasions, we catch a keeper. Then he takes out his
Swiss Army knife and teaches me to gut, clean, and filet.
His hair sparkles with scattered fish scales. So does mine.
Often we spread a picnic: black bread, smelly cheese, a tin
of sardines. I eat only my share.
- 32 At nineteen, during my college vacation, I fly out to join
my parents in Japan. My father and I climb Mount Fuji.
High above the Pacific, and hours up the cindery slope, we
picnic on dried eel, seaweed crackers, cold rice wrapped in
the skin of an eel. He reaches the peak first.
- 33 Through years we hike along a beach in Cyprus, beside
a river in Lebanon, the Seine, Alpine streams, and picnic by
various other waters and weathers. We overtake one
another. I've never known anyone with such energy.

* * *

- 34 Time rots like old fish.
- 35 Today in the nursing home in Virginia I beg him,
"Please, Daddy, just a little walk. You are supposed to
exercise."
- 36 The nurses are supposed to walk him daily, but they are
always too busy. I try to walk him whenever I visit, but
seldom lately has he felt up to more than a step or two.
- 37 "Come, Daddy, forward, march . . ."

38 He can't get out of his chair. I've forgotten to untie the straps of the "posey" which restrains him. Not that he often gets up on his own, but once in a while he'll suddenly have a spurt of strength, then is likely to topple over. I crouch to lift his feet from the foot pedals, fold back the metal pieces which too often bruise his paperthin skin.

39 "Come, now you can stand."

40 He struggles, but cannot move. I place his hands on the rubberized handholds on the metal walker. "Hold tightly and you can pull yourself up."

41 He grips the walker and struggles forward. He still cannot make it to his feet. I am about to lift him, when the nurse comes down the corridor.

42 "Lunch trays are up," she calls out. "Everyone hurry to the solarium!"

43 As if anyone here could do much hurrying.

44 I push his wheelchair to the dining room. His plastic plate is heaped with pureed tuna—he's been having trouble swallowing lately—but he ignores his lunch. The ice cream turns to milk in its styrofoam dish.

45 I hand him a spoon. It slips from his fingers. Some days I sing him old songs, tell stories, but one of the residents turns the television on full blast and he can't even hear my repeated, "Won't you eat, Daddy, please?"

46 I lift a spoonful of grey fishy stuff to his mouth.

47 He whispers, politely, "I don't care for any."

48 Nor would I.

49 Suddenly I go into action, wheel him to the nurses' station, sign him out for the afternoon. It has been a while since I've taken him out, the weather has been too cold or too hot, I haven't had time between work and children and travels, he has had so many bad days of late, he has often been asleep when I've come by, it's a hassle to get him into the car, and how much would he take in anymore anyway.

50 We head full speed for the elevator, downstairs, out the main door, out into the parking lot. An orderly helps me get him into my car, and fits the folded wheelchair into the trunk. I adjust our seat belts.

51 Off we go, down the road, over the bridge toward town.

52 “We’re crossing the Potomac River now, Daddy. Ahead are the Kennedy Center and Watergate, and to the right—can you see the Washington Monument? Remember when we climbed up there, ignored the elevator? And the Smithsonian Museum—how many rainy Saturdays did we spend in museums? And look at those flower beds—”

53 He doesn’t say much to my running travelogue, but seems to be staring out the car window and taking in at least something of a scene he used to know well. The sky is very blue, and so is the river.

54 We turn south from Independence Avenue past some warehouses and pull in by my favorite wholesale fish market.

55 “I’ll be back in a moment, Daddy. Please wait for me—”

56 As if he had a choice.

57 Inside the cool building men in hip boots are sloshing around carrying 16-pound sea trout by the tails. Fish scales fly through the moist air. Frozen boxes of squid and string bags of clams are awaiting pick-up for some restaurant. A curly-haired man is hosing down the floor. I step over the puddles and ask him if by any chance he has any eel today.

58 “We haven’t had any in a year, Ma’am. But it just happens that today—if you don’t mind smoked eel—”

59 He wraps a large chunk in waxy white paper. I pay and hurry out to the car where my father is watching with interest a forklift loading crates of mussels into a truck.

60 “I’ve brought you a surprise.”

61 “Why, thank you, dear!” His voice is stronger than I’ve heard it for months, and he stretches forward for the package with interest. He loves presents, and reaches with awkward fingers to try to open it. The smell fills the car. His fingers can’t undo it, but he holds it while I drive down to the river and find a parking place near the marina. Somehow I wrestle the wheelchair from the car, set it up, wrestle him into it, push him out to a level area.

62 “I’d like a bit of a walk,” he says clearly.

63 Gradually I lift and push and pull him to his feet. Now he is standing, unsteadily, then gains a sort of balance.

64 “See, you made it! That’s wonderful . . . First take a deep breath . . . All right? I’ll be right behind you, my hand is in the small of your back. Now—Forward, march!”

65 He shuffles a couple of steps along the quai. I am holding him securely, somehow maneuvering the wheelchair behind him in case he gets tired. I steady him as he pauses to watch the sail and motorboats on the river. He manages a few more steps, and a few more, along the quai. He hasn't walked this far in months, and seems pleased with himself. There is a small bench ahead and, abandoning the wheelchair, we sit down together.

66 Again for the first time in months, he begins to talk. He remarks on the red dress of a young woman striding by, he wonders what day it is, he inquires about the children. It is some sort of a miracle, this return to "normalcy," however brief. I cherish every instant.

67 "And what about your dinner plans?" he asks with his old graciousness, and invites me out for supper. Of course I accept, we'll manage it somehow. Meanwhile, it is only mid-afternoon, too soon for restaurants, but he has worked up an appetite.

68 I run over and buy something like lemonade from a vendor. Then I take the small smelly package wrapped in glazed ivory paper from its plastic bag.

69 "Look, Daddy. The fishmonger actually had some smoked eel."

70 We unwrap it, then I take out the Swiss Army knife my stepmother gave me "for safekeeping," open the bottles and thinly slice the silvery flesh.

71 "What a beautiful picnic," my father beams.

72 He takes a swig of the lemonade, then with steady fingers picks up a slice of eel and downs it without difficulty. Then another, and another, until he eats the whole chunk.

"In Search of Eels," by Elisavietta Ritchie, from *THE TIE THAT BINDS*, Papier-Mache Press, 1988 and 1992, and *FLYING TIME: STORIES & HALF-STORIES*, copyright © 1992 and 1996 Elisavietta Ritchie. Reprinted by permission of the author.

Living an Adventurous Life

by Nancy Mairs

My notes about what I am
reading

1 Nearly ten years ago, I was told that I had a brain tumor, and this experience changed my attitude about adventure forever. I thought that I was going to die and that all my adventures were over. I did not have a brain tumor, it turned out, but rather multiple sclerosis, which meant that, although they were not over, the nature of my adventures would have to change.

2 Each morning that I wake up, that I get out of bed, is a fresh event, something that I might not have had. Each gesture that I make carries the weight of uncertainty, demands significant attention: buttoning my shirt, changing a light bulb, walking down stairs. I might not be able to do it this time. Inevitably the minutiae of my life have had to assume dramatic proportions. If I could not delight in them, they would likely drown me in rage and in self-pity.

3 I admire the grand adventures of others. I read about them with zest. With Peter Matthiessen I have trekked across the Himalayas to the Crystal Mountain. One blistering July I moved with John McPhee to Eagle, Alaska, above the Arctic Circle. I have trudged with Annie Dillard up, down, into, and across Tinker Creek in all seasons. David Bain has accompanied me along 110 miles of Philippine coast, and Ed Abbey has paddled me down the Colorado River. I've ridden on the back of Robert Pirsig's motorcycle, climbed 95 feet to George Dyson's tree house, and grown coffee in Kenya with Isak Dinesen. I relish the adventures of these rugged and courageous figures, who can strike out on difficult trips—2 miles, 250 miles, 3,000 miles—ready to endure cold, fatigue, human and natural hostility—indeed not just to endure but to celebrate.

4 But as for me, I can no longer walk very far from the armchair in which I read. I'll never make it to Tibet. Maybe not even to Albuquerque. Some days I don't even make it to the backyard. And yet I'm unwilling to forgo the adventurous life: the difficulty of it, even the pain, the suspense and fear, and the sudden brief lift of spirit that graces a hard journey. If I am to have it too, then I must change the terms by which it is lived. And so I do.

5 I refine *adventure*, make it smaller and smaller. And now, whether I am feeding fish flakes to my bettas or crawling across the dining room helping my cat Burton look for his blind snake, lying wide-eyed in the dark battling yet another bout of depression, cooking a chicken, gathering flowers from the garden at the farm, meeting a friend for lunch, I am always having the adventures that are mine to have.

Excerpt from "On Having Adventures" from Plaintext, by Nancy Mairs. Copyright © 1986 The Arizona Board of Regents. Reprinted by permission of the University of Arizona Press.

My notes about what I am reading

Vision VOLUNTEERS

The Adventure You've Been Waiting For!

Are you willing to spend your summer in the
Grand Canyon? How about in the mountains of Peru?



Vision can take
you places. Our
volunteers spend two
months each summer
helping out in some of
the most beautiful
places in the world.

Volunteers help archaeologists catalog ancient ruins in
Machu Picchu. They mark trails with park rangers and
assist campers in U.S. national parks. They count
loggerhead turtle eggs in Florida.

Experience the adventure of a lifetime. Become a
Vision Volunteer. Learn how inside.

Where will Vision lead you?

Photographs courtesy of © Blaine Harrington III and Lynda Richardson/CORBIS.

**Use “Living an Adventurous Life” (pp. 10–11)
to answer questions 13–22.**

13 Read the following dictionary entry.

refine \ri-ˈfīn\ *v* **1.** to elevate **2.** to remove moral imperfections **3.** to cultivate **4.** to alter by polishing or reducing

Which definition best matches the use of the word *refine* in paragraph 5?

- A Definition 1
- B Definition 2
- C Definition 3
- D Definition 4

14 Nancy Mairs was first diagnosed as having —

- F multiple sclerosis
- G cerebral palsy
- H depression
- J a brain tumor

15 Mairs admires the people named in paragraph 3 because they are —

- A physically handicapped
- B amusing
- C adventurers
- D fiction writers

16 This selection is mainly about —

- F the author’s adjustment to life with multiple sclerosis
- G the excitement that can be shared through books
- H the author’s depression about giving up certain activities
- J traveling to several foreign countries

17 The author has found a resolution to her conflict by —

- A meeting with a medical specialist
- B expressing her anger each day
- C defining adventure in a new way
- D adopting several pets who need care

18 In which line from the selection does the author use an allusion?

- F *With Peter Matthiessen I have trekked across the Himalayas to the Crystal Mountain.*
- G *But as for me, I can no longer walk very far from the armchair in which I read.*
- H *I’ll never make it to Tibet.*
- J *I am always having the adventures that are mine to have.*

19 The tone of this selection is —

- A mysterious
- B optimistic
- C suspenseful
- D detached

20 In paragraph 3, why does the author say that she was with the participants as she was reading about them?

- F She is emphasizing the idea that a person can be transported by books.
- G She is feeling embarrassed that her illness confines her to her home.
- H She is conveying a feeling of kinship with disabled people around the world.
- J She is referring to a time in the past when she traveled extensively.

21 Paragraph 1 suggests that before her diagnosis Mairs had a —

- A love of reading literature
- B fear of pursuing adventures
- C conventional understanding of adventure
- D constant dread of medical procedures

22 The author uses paragraphs 3 and 5 to —

- F reveal the scope of the adventures she experiences
- G describe the difficult lives of twentieth-century writers
- H explain the benefits that can be derived from reading
- J chronicle the events of one of her typical days

**Use “In Search of Eels” and “Living an Adventurous Life” (pp. 4–11)
to answer questions 23–25.**

- 23** Which of these is a theme shared by both selections?
- A** Reading is an activity that everyone can enjoy.
 - B** A positive attitude can improve a difficult situation.
 - C** A person’s outlook can be improved through physical exercise.
 - D** Travel can enrich a person’s education.
- 24** The reader can conclude that the authors of “In Search of Eels” and “Living an Adventurous Life” —
- F** have not traveled extensively
 - G** enjoy spending time reading and gardening
 - H** are willing to try new ways of enriching their lives
 - J** feel bitter and angry about their current circumstances
- 25** Both Ritchie and Mairs end their selections with a feeling of —
- A** conceit
 - B** despair
 - C** celebration
 - D** satisfaction

**Use the visual representation on page 12
to answer questions 26–28.**

26 People who want to learn more about Vision Volunteers can —

- F** continue reading the brochure
- G** attend a meeting in Florida
- H** wait for a volunteer to call
- J** ask their local park ranger

28 The brochure's designer most likely chose the two photographs to illustrate —

- F** places volunteers might work
- G** different modes of transportation
- H** national park trails in Florida
- J** the life cycle of loggerhead turtles

27 The purpose of this brochure is to —

- A** inform readers about the mountains of Peru
- B** entertain readers with a story about travel
- C** convince readers to join Vision Volunteers
- D** show readers how volunteers are recruited

DIRECTIONS

Answer the following questions in the space provided on the answer document.

- 29** Explain how the narrator's actions reveal her feelings for her father in "In Search of Eels." Support your answer with evidence from the selection.
- 30** Do you think that Nancy Mairs in "Living an Adventurous Life" is adventurous? Explain your answer and support it with evidence from the selection.
- 31** What is one similarity between the narrators in "In Search of Eels" and "Living an Adventurous Life"? Support your answer with evidence from **both** selections.

BE SURE YOU HAVE WRITTEN YOUR ANSWERS
ON THE ANSWER DOCUMENT.



WRITTEN COMPOSITION

Write an essay explaining the value of the small, everyday events of life.

The information in the box below will help you remember what you should think about when you write your composition.

REMEMBER—YOU SHOULD

- write about the assigned topic
- make your writing thoughtful and interesting
- make sure that each sentence you write contributes to your composition as a whole
- make sure that your ideas are clear and easy for the reader to follow
- write about your ideas in depth so that the reader is able to develop a good understanding of what you are saying
- proofread your writing to correct errors in spelling, capitalization, punctuation, grammar, and sentence structure

USE THIS PREWRITING PAGE TO
PLAN YOUR COMPOSITION.

MAKE SURE THAT YOU WRITE YOUR COMPOSITION ON
THE TWO LINED PAGES IN THE ANSWER DOCUMENT.

USE THIS PREWRITING PAGE TO
PLAN YOUR COMPOSITION.

MAKE SURE THAT YOU WRITE YOUR COMPOSITION ON
THE TWO LINED PAGES IN THE ANSWER DOCUMENT.

USE THIS PREWRITING PAGE TO
PLAN YOUR COMPOSITION.

MAKE SURE THAT YOU WRITE YOUR COMPOSITION ON
THE TWO LINED PAGES IN THE ANSWER DOCUMENT.

Revising and Editing Sample

DIRECTIONS

Read the introduction and the passage that follows. Then read each question and fill in the correct answer on page 2 of your answer document.

Lydia has written this report for her U.S. history class. As part of a peer conference, you have been asked to read the report and think about what suggestions you would make. When you finish reading the report, answer the questions that follow.

The American Red Cross

(1) The American Red Cross is an organization that aids people all around the world. (2) It started as a result of the efforts of a dedicated woman. (3) That woman was named Clara Barton. (4) It was during the Civil War that Barton began the work that lead to the establishment of the American Red Cross. (5) She assisted on the battlefield by nursing injured soldiers and helping transport supplies. (6) Eventually the Government of the United States selected her to serve as superintendent of nurses for the army.

- S-1** What is the most effective way to combine sentences 2 and 3?
- A** It started as a result of the efforts of a dedicated woman, that woman was named Clara Barton.
 - B** It started as a result of the efforts of a woman who was dedicated and named Clara Barton.
 - C** It started as a result of the efforts of a dedicated woman named Clara Barton.
 - D** It started as a result of the efforts of a dedicated woman she was named Clara Barton.

- S-2** What change, if any, should be made in sentence 4?
- F** Change *was* to **is**
 - G** Insert a comma after *Civil War*
 - H** Change *lead* to **led**
 - J** Make no change

- S-3** What change, if any, should be made in sentence 6?
- A** Change *Government* to **government**
 - B** Change *selected* to **sellected**
 - C** Change *her* to **herself**
 - D** Make no change



REVISING AND EDITING

DO NOT GO ON TO THE REVISING AND EDITING SECTION.
WHEN YOU FINISH THE READING AND WRITTEN
COMPOSITION SECTION, RAISE YOUR HAND AND WAIT
FOR A TEST ADMINISTRATOR TO ASSIST YOU.



DIRECTIONS

Read the following passages and mark your answers on page 2 of your answer document. Remember that you are NOT permitted to use dictionaries or other reference materials on this section of the test.

At the park Angela saw an unusual dog. After talking with the dog's owner, Angela wrote this paper. She would like your help in revising and editing it. As you read Angela's paper, think about the corrections and improvements she should make. Then answer the questions that follow.

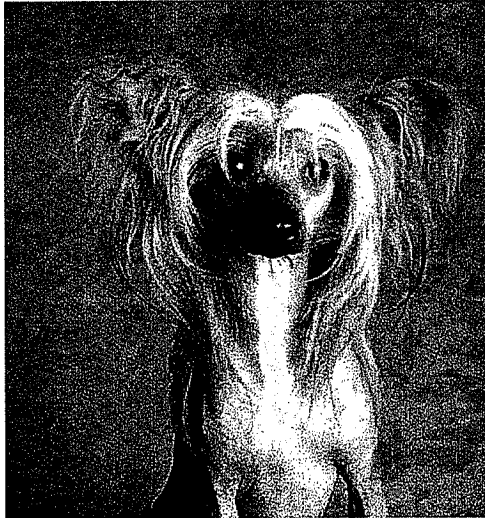

Photo courtesy of © Robert Dowling/CORBIS.

Hairless Dogs

(1) There is good news for allergy sufferers who are also pet lovers. (2) Most people who cough and sneeze around furry pets they can happily co-exist with several breeds of hairless dogs.

(3) In the United States the most common hairless dog probably the Chinese crested. (4) This dog has very little hair—just a crest on its head and tufts on its feet and the tip of its tail. (5) Its skin can be almost any color, including white, pink, or blue. (6) The soft skin feels warm to the touch because, as is the case with most hairless breeds, the body temperature of the Chinese crested is noticeably higher than that of a furry canine.

(7) Another hairless breed is the xoloitzcuintle (pronounced sho-lo-eets-

hairless. (9) Mexico is a country that is known for its moderate climate.

(10) Clay figures and remains of the xolo has been found among Aztec and Mayan ruins.

(11) Some interesting stories are associated with another type of hairless dog, the Peruvian hairless. (12) One story says that during the day Incan nobles keep these dogs in climate-controlled rooms that housed orchids. (13) This was supposed to protect the animals' sensitive skin from the sun. (14) At night the dogs were allowed to run outside in the moonlight. (15) This hairless breed is sometimes called the Inca orchid dog or the moonflower dog.

(16) Some people like hairless dogs because these pets are so easy to keep clean. (17) They rarely have fleas, are easy to bathe and dry, and require little grooming. (18) Their bare skin is sensitive, however, and must be carefully protected from harsh weather. (19) These dogs need to wear sunscreen or a shirt when exposed to the sun. (20) In cold weather, a sweater or jacket is a must.

(21) In the case of hairless breeds, beauty is truly in the eye of the beholder. (22) While some people find these dogs ugly and bizarre, others find them beautiful and intriguing. (23) It is for sure that hairless dogs are definitely not the most popular dogs in this country. (24) In fact, they are a rare sight in many places. (25) Still, the "bare" truth of the matter is that throughout the century's, hairless dogs have made perfect pets and suitable companions for dog lovers all over the world.

32 What change, if any, should be made in sentence 2?

- F Change *who* to **that**
- G Delete *they*
- H Change *happily* to **happy**
- J Make no change

33 What change, if any, should be made in sentence 3?

- A Change *most common* to **commonest**
- B Insert **is** after *dog*
- C Change *probably* to **proably**
- D Make no change

34 What change should be made in sentence 6?

- F Change the comma after *breeds* to a semicolon
- G Change *noticeably* to **noticably**
- H Change *higher* to **more high**
- J Change *then* to **than**

35 What change, if any, should be made in sentence 10?

- A Change *remains* to **remain's**
- B Change *has been found* to **have been found**
- C Change *ruins* to **Ruins**
- D Make no change

36 What is the most effective way to improve the organization of the third paragraph (sentences 7–10)?

- F Delete sentence 7
- G Switch sentences 7 and 8
- H Move sentence 8 to the end of the paragraph
- J Delete sentence 9

37 What change, if any, should be made in sentence 12?

- A Change *says* to **saying**
- B Insert **they** after *nobles*
- C Change *keep* to **kept**
- D Make no change

38 What transition could be added to the beginning of sentence 15?

- F However,
- G In contrast,
- H Consequently,
- J Meanwhile,

39 What change, if any, should be made in sentence 18?

- A Change *Their* to **There**
- B Delete the comma after *however*
- C Change *carefully* to **carefully**
- D Make no change

40 What is the most effective way to rewrite sentence 23?

- F They are not the most popular hairless dogs in this country, that's for sure.
- G Hairless dogs are definitely not the most popular dogs in this country.
- H It is for sure that hairless dogs. They are definitely not the most popular dogs in this country.
- J Hairless dogs are definitely not the most popular dogs for sure in this country.

41 What change, if any, should be made in sentence 25?

- A Change *century's* to **centuries**
- B Change *have made* to **make**
- C Change *companions* to **companons**
- D Make no change

In this paper Aidan describes an emotional experience from two points of view. Read his paper and look for the corrections and improvements that Aidan should make. Then answer the questions that follow.

The Homecoming

(1) Overseas duty forces many military men and women to leave their family for extended periods of time. (2) These departures are often accompanied by tears and concerns. (3) There can be months—sometimes even years—of loneliness and worry, of being unable to share problems and celebrations. (4) But family members always look forward to the joy of reuniting, a joy that is especially bright in contrast to the time spent waiting. (5) The time apart usually change people—both those who go and those who stay. (6) As a result, most homecoming reunions have a story. (7) This is one of them.

* * *

(8) Sergeant Walker Roth dropped his duffel bag on the airport floor. (9) His jaw dropped in surprise. (10) His mouth stretched into a grin. (11) It was a smile formed from happiness and disbelief. (12) He couldn't believe he was looking at his son Collin. (13) In just 18 months the pudgy, round-faced grade-schooler had become a lanky junior-high preteen!

(14) The boy had been so frightened; when Roth had said good-bye. (15) He had clutched his mother's hand desperately. (16) Now it was his mother who seemed more anxious. (17) As she nervously scanned the crowd for a glimpse of her husband, Collin looped his arm protective through hers. (18) He patted her

hand reassuringly. (19) Roth noticed the motion. (20) He had been stationed overseas for a year and a half, and he could see that his boy had grown in more than just height. (21) The father's heart swelled with pride.

* * *

(22) Collin spotted his father immediately. (23) In his brass-buttoned uniform, he looked taller and broader than Collin remembered. (24) Every day since his father had left, Collin had looked at the picture beside his bed. (25) It showed his father standing on a dock, he was shading his smiling face from the sun. (26) The man in the airport looked older, and even though he was smiling, his eyes looked more serious. (27) He looked weathered and tired, too. (28) With one hand Collin pulled his mother forward. (29) Up to his face in a motion, and it was half-wave and half-salute, went his other hand. (30) It was time to greet his father—his hero! (31) The son's heart swelled with pride.

- 42 What change, if any, should be made in sentence 3?
- F Change *loneliness* to *lonely*
 - G Change *of being* to *you are*
 - H Change *celabrations* to *celebrations*
 - J Make no change

- 43 What change, if any, should be made in sentence 5?
- A Insert it after *apart*
 - B Change *change* to *changes*
 - C Change *and* to *nor*
 - D Make no change

- 44 Which transition word or phrase could be added to the beginning of sentence 10?
- F Previously
 - G After a moment
 - H For instance,
 - J Therefore,

- 45 What change, if any, should be made in sentence 11?
- A Insert it after *smile*
 - B Insert a comma after *happiness*
 - C Change *disbeleif* to *disbelief*
 - D Make no change

- 46 What change, if any, should be made in sentence 14?
- F Change *had been* to *having been*
 - G Change *frightened* to *frightfully*
 - H Delete the semicolon
 - J Make no change

- 47 What change, if any, should be made in sentence 15?
- A Change *clutched* to *cluched*
 - B Change *mothers'* to *mother's*
 - C Change *desperately* to *desperate*
 - D Make no change

48 What change should be made in sentence 17?

- F Change *scanned* to *scaned*
- G Delete the comma
- H Change *his* to *her*
- J Change *protective* to *protectively*

49 What revision, if any, is needed in sentence 24?

- A Every day since his father had left, Collin had looked at the picture beside his bed.
- B Every day since his father had left, Collin had looked at it. The picture beside his bed.
- C Every day since his father had left, Collin had looked at the picture, it was beside his bed.
- D No revision is needed.

50 What revision, if any, is needed in sentence 25?

- F It showed his father standing on a dock, shading his smiling face from the sun.
- G It showed his father standing on a dock. Shading his smiling face from the sun.
- H It showed his father. Who was standing on a dock, shading his smiling face from the sun.
- J No revision is needed.

51 What is the most effective way to revise sentence 29?

- A His other hand went up to his face in a motion, it was half-wave and half-salute.
- B His other hand went up to his face. In a motion that was half-wave and half-salute.
- C His other hand went up to his face in a motion. A half-wave and half-salute motion.
- D His other hand went up to his face in a motion that was half-wave and half-salute.

BE SURE YOU HAVE RECORDED ALL OF YOUR ANSWERS
ON THE ANSWER DOCUMENT.



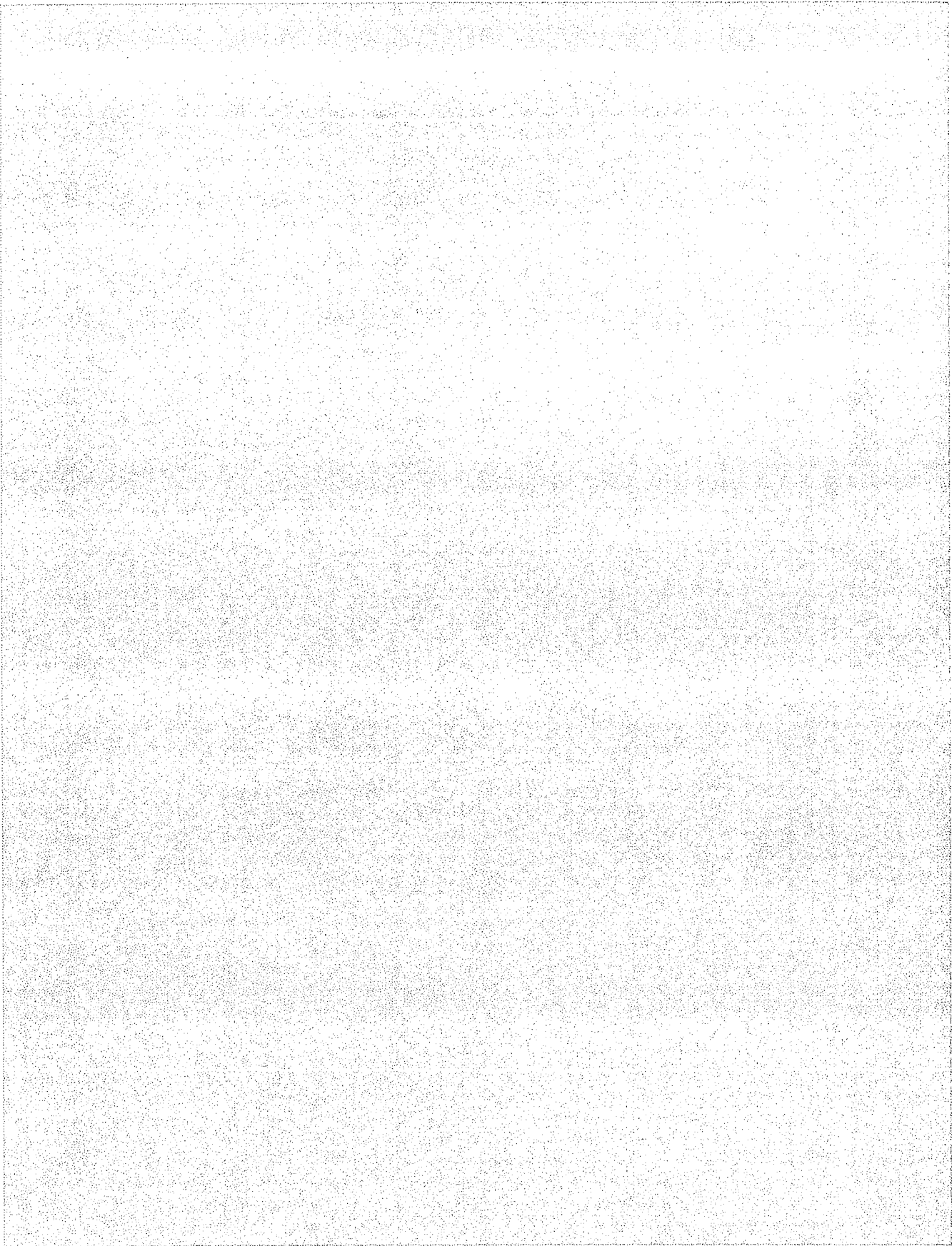

MATHEMATICS

Mathematics Chart

LENGTH

Metric

1 kilometer = 1000 meters

1 meter = 100 centimeters

1 centimeter = 10 millimeters

Customary

1 mile = 1760 yards

1 mile = 5280 feet

1 yard = 3 feet

1 foot = 12 inches

CAPACITY AND VOLUME

Metric

1 liter = 1000 milliliters

Customary

1 gallon = 4 quarts

1 gallon = 128 ounces

1 quart = 2 pints

1 pint = 2 cups

1 cup = 8 ounces

MASS AND WEIGHT

Metric

1 kilogram = 1000 grams

1 gram = 1000 milligrams

Customary

1 ton = 2000 pounds

1 pound = 16 ounces

TIME

1 year = 365 days

1 year = 12 months

1 year = 52 weeks

1 week = 7 days

1 day = 24 hours

1 hour = 60 minutes

1 minute = 60 seconds

Metric and customary rulers can be found on the separate Mathematics Chart.

Mathematics Chart

Perimeter	rectangle	$P = 2l + 2w$ or $P = 2(l + w)$
Circumference	circle	$C = 2\pi r$ or $C = \pi d$
Area	rectangle	$A = lw$ or $A = bh$
	triangle	$A = \frac{1}{2}bh$ or $A = \frac{bh}{2}$
	trapezoid	$A = \frac{1}{2}(b_1 + b_2)h$ or $A = \frac{(b_1 + b_2)h}{2}$
	circle	$A = \pi r^2$
Surface Area	cube	$S = 6s^2$
	cylinder (lateral)	$S = 2\pi rh$
	cylinder (total)	$S = 2\pi rh + 2\pi r^2$ or $S = 2\pi r(h + r)$
	cone (lateral)	$S = \pi rl$
	cone (total)	$S = \pi rl + \pi r^2$ or $S = \pi r(l + r)$
	sphere	$S = 4\pi r^2$
Volume	prism or cylinder	$V = Bh^*$
	pyramid or cone	$V = \frac{1}{3}Bh^*$
	sphere	$V = \frac{4}{3}\pi r^3$
<i>*B represents the area of the Base of a solid figure.</i>		
Pi	π	$\pi \approx 3.14$ or $\pi \approx \frac{22}{7}$
Pythagorean Theorem		$a^2 + b^2 = c^2$
Distance Formula		$d = \sqrt{(x_2 - x_1)^2 + (y_2 - y_1)^2}$
Slope of a Line		$m = \frac{y_2 - y_1}{x_2 - x_1}$
Midpoint Formula		$M = \left(\frac{x_1 + x_2}{2}, \frac{y_1 + y_2}{2} \right)$
Quadratic Formula		$x = \frac{-b \pm \sqrt{b^2 - 4ac}}{2a}$
Slope-Intercept Form of an Equation		$y = mx + b$
Point-Slope Form of an Equation		$y - y_1 = m(x - x_1)$
Standard Form of an Equation		$Ax + By = C$
Simple Interest Formula		$I = prt$

DIRECTIONS

Read each question. Then fill in the correct answer on your answer document. If a correct answer is not here, mark the letter for "Not here."

SAMPLE A

Find the slope of the line $2y = 8x - 3$.

A $-\frac{3}{2}$

B 4

C 8

D Not here

SAMPLE B

Janice uses a rectangular box to store her art supplies. The dimensions of the rectangular box are 22.5 inches by 14 inches by 11.5 inches. What is the volume of this box in cubic inches?

Record your answer and fill in the bubbles on your answer document. Be sure to use the correct place value.



- 1 The graph of the equation $y = 0.4x^2 - 2$ is shown below.

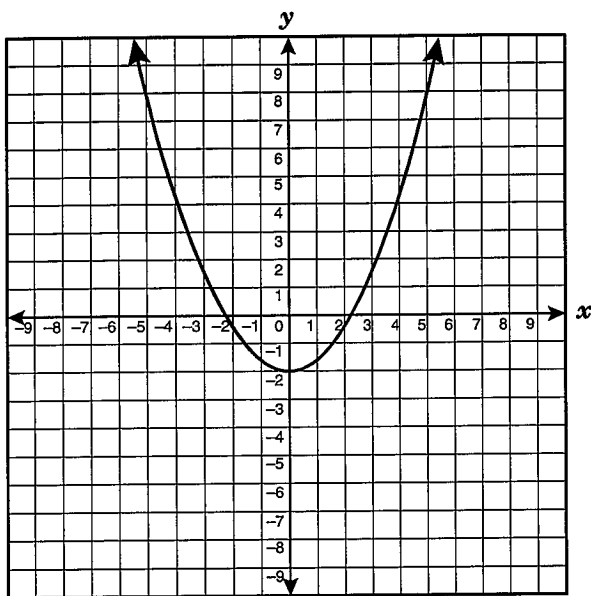

If the graph is translated 3 units up, what will be the equation of the resulting graph?

- A $y = 0.4x^2 + 1$
- B $y = 0.7x^2 - 2$
- C $y = 0.4x^2 + 5$
- D $y = 3.4x^2 - 2$

- 2 A basketball player made 12 free throws in his last 36 attempts. How many free throws would the basketball player be expected to make in 78 attempts?

- F 20
- G 26
- H 52
- J 234

- 3 George saves 15% of his total gross weekly earnings from his 2 part-time jobs. He earns \$6.15 per hour from one part-time job and \$7.25 per hour from the other part-time job. George works a total of 40 hours between the two jobs each week. What additional information is needed to determine the amount of his earnings he saves each week?

- A The number of days he works at each job
- B The number of hours he works at each job
- C The number of hours he works each day
- D The number of hours he works each month

4 Which net best represents the hexagonal prism shown below?

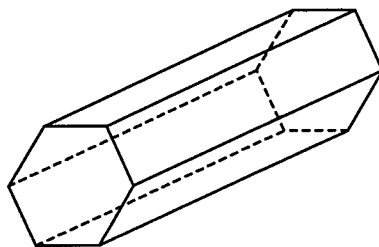

F

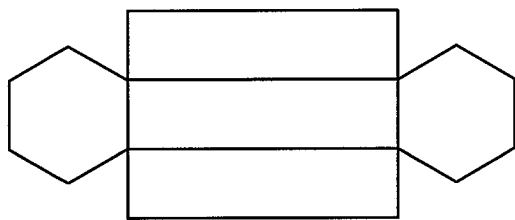

H

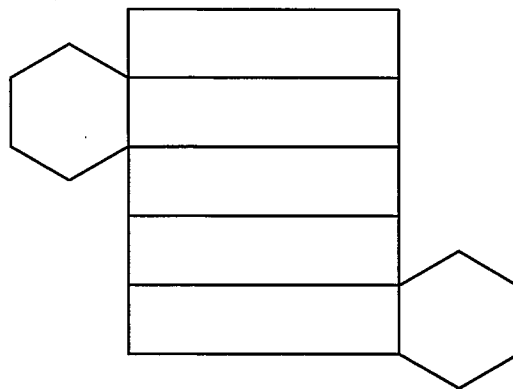

G

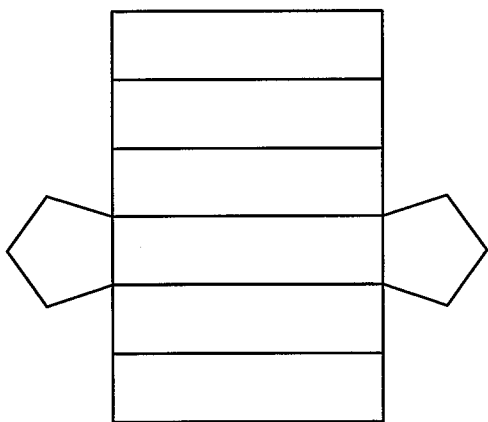

J

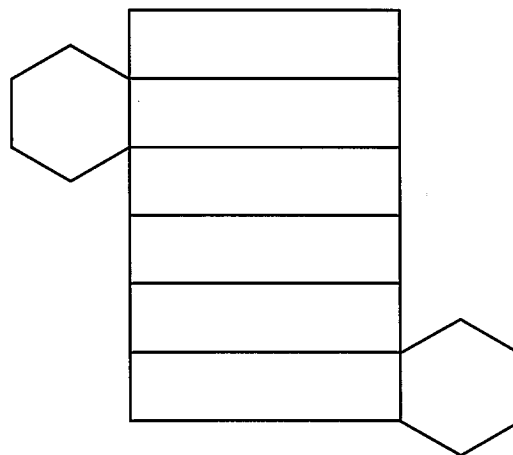

- 5 A function is described by the equation $y = 2x^2 - 5x - 3$, in which y is dependent on x . If a value for the independent variable is selected from the set $\{-4, -1, 0, 2, 5\}$, which of the following is a corresponding dependent value?

- A 9
- B -6
- C -5
- D 0

- 6 The drama department at McHenry High School has built a stage floor in the shape of a regular octagon. The length of each side of the octagon is 4 yards.

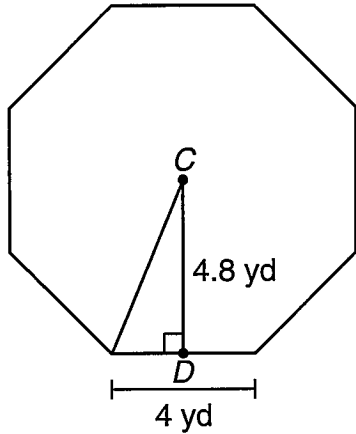

\overline{CD} is the apothem. What is the approximate area of the stage floor?

$$[\text{Area} = \frac{1}{2}(\text{apothem})(\text{perimeter})]$$

- F 57.9 yd^2
- G 76.8 yd^2
- H 115.9 yd^2
- J 154.5 yd^2

- 7 The graph shows quadrilateral $TUVW$, \overline{KN} , and \overline{KL} .

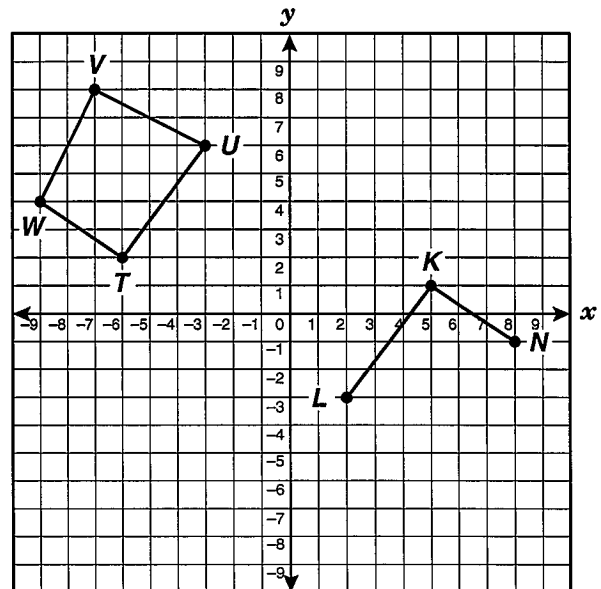

At what coordinate point should vertex M be placed to make quadrilateral $KLMN$ congruent to quadrilateral $TUVW$?

- A $(6, -4)$
- B $(4, -5)$
- C $(5, -5)$
- D $(6, -5)$

8 The graph below shows the relationship between temperature and the density of water.

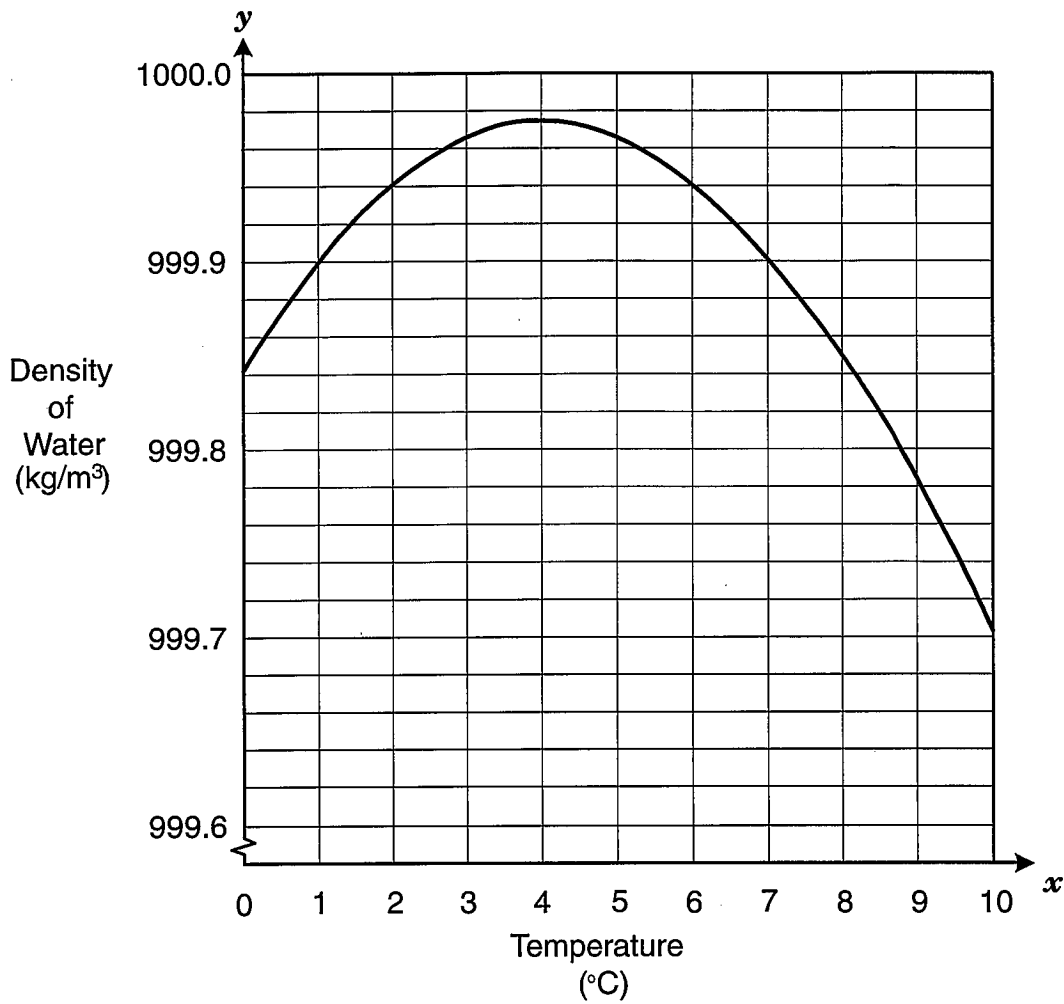

Which of the following statements best describes this relationship?

- F The density of water increases as temperature increases between 4°C and 10°C.
- G The density of water decreases as temperature increases between 0°C and 4°C.
- H The density of water decreases as temperature increases between 4°C and 10°C.
- J The density of water remains constant as temperature increases.

- 9 An investor has a total of 45 one-ounce ingots, made of either gold or silver, worth \$7636.50. The value of a gold ingot is \$280.00, and the value of a silver ingot is \$4.25. Which system of equations can be used to find g , the number of gold ingots, and s , the number of silver ingots?

- A $g - s = 45$
 $280.00g + 4.25s = 7636.50$
- B $g + s = 45$
 $280.00g + 4.25s = 7636.50$
- C $g + s = 45$
 $4.25g + 280.00s = 7636.50$
- D $g - s = 7636.50$
 $280.00g + 4.25s = 45$

- 10 If $XY = 8$ feet and $XZ = 17$ feet, what is the area of $\triangle XYZ$?

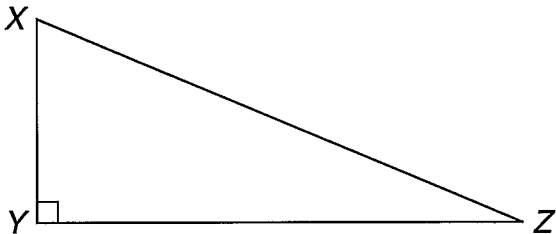

- F 15 ft^2
- G 30 ft^2
- H 60 ft^2
- J 120 ft^2

- 11 What is the approximate distance between points $(-7, 2)$ and $(11, -5)$?

- A 18.36 units
- B 19.31 units
- C 18.25 units
- D 8.06 units

- 12 The graphs below represent functions of the form $y = ax^2$. In which of the following graphs does a have the smallest value?

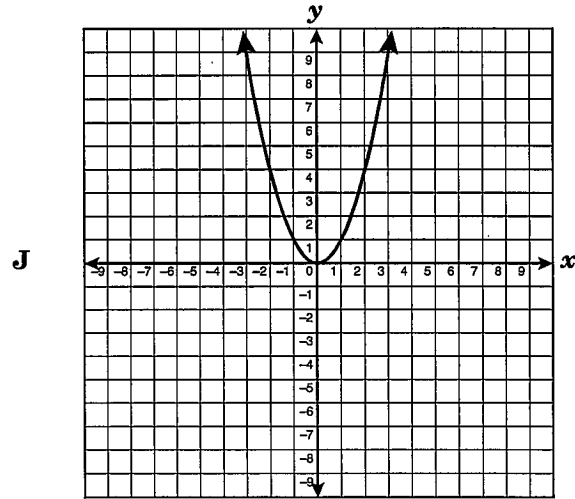
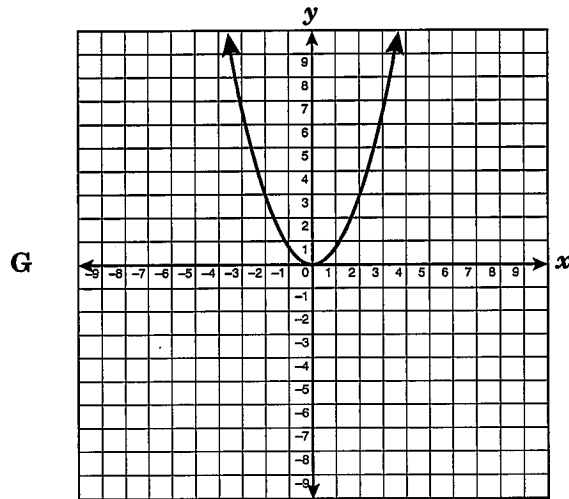
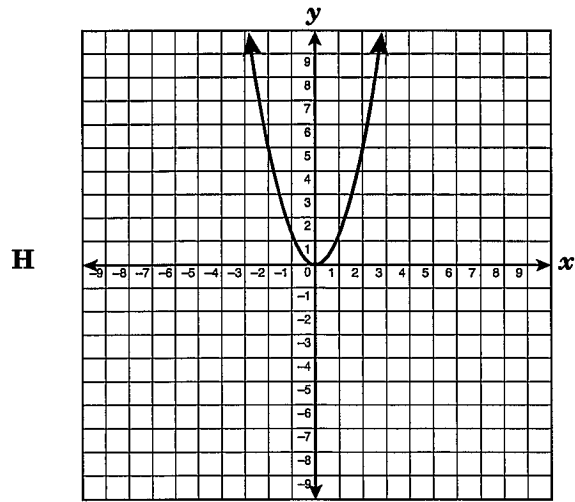
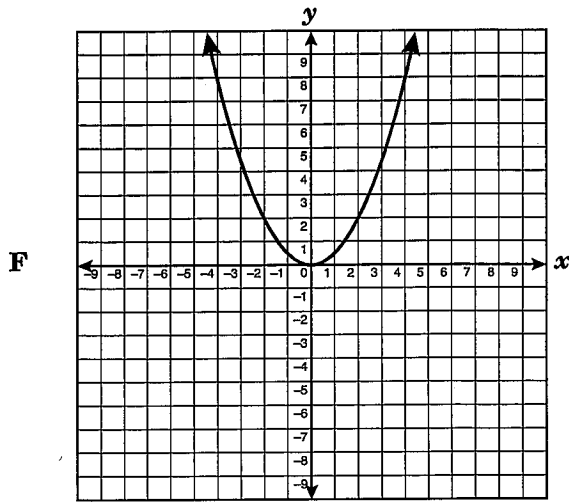

- 13 Line a intersects line b and line c , as shown below.

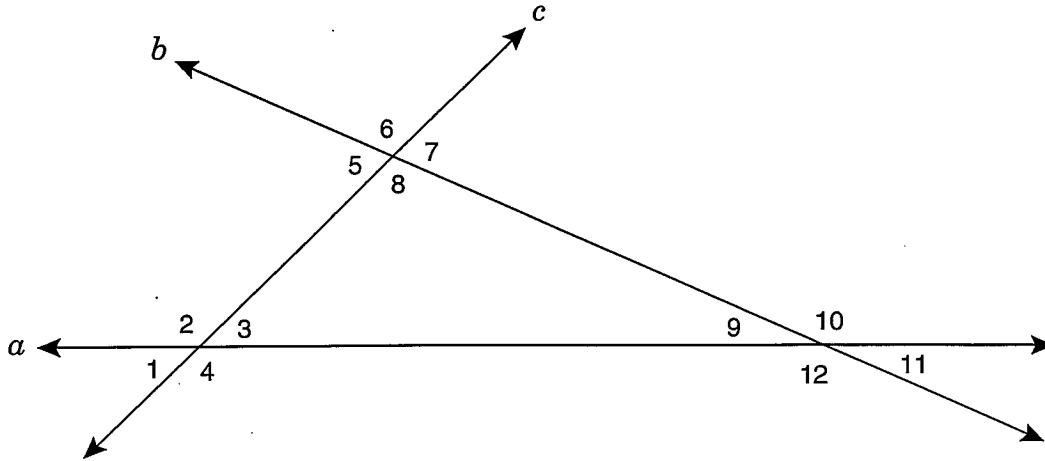

Which of the following angle relationships must be true?

- A $m\angle 2 + m\angle 6 + m\angle 10 = 180^\circ$
B $m\angle 3 + m\angle 6 + m\angle 12 = 180^\circ$
C $m\angle 1 + m\angle 6 + m\angle 11 = 180^\circ$
D $m\angle 4 + m\angle 6 + m\angle 9 = 180^\circ$
-
- 14 The initial pressure inside a closed container is 200 pounds per square inch (psi). As the temperature inside the container increases, the pressure increases. If the pressure increases 7.5 psi for each degree Fahrenheit of increased temperature, which equation best represents p , the pressure inside the container after the temperature has increased t degrees?
- F $p = 7.5t$
G $p = 200 + 7.5t$
H $p = 200t + 7.5$
J $p = 200t + 7.5t$

15 What is the apparent slope of the line graphed below?

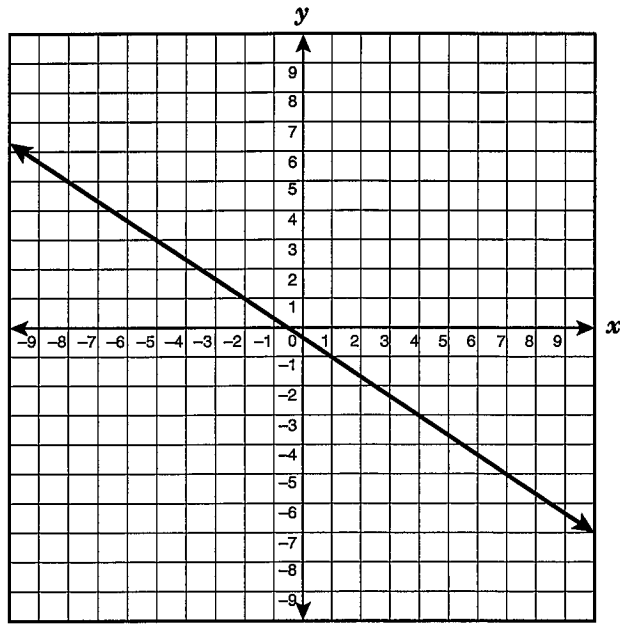

A $-\frac{3}{2}$

B $\frac{2}{3}$

C $\frac{3}{2}$

D $-\frac{2}{3}$

- 16 A total of 550 students from the Fairfield High School junior class voted on their choice for their senior class gift to the school. The table below shows the results of the vote.

Senior Class Gift

Type	Number of Votes
Mural	220
Statue	88
Garden	77
Scholarships	121
Other	44

Which graph best represents the results of the survey?

Senior Class Gift

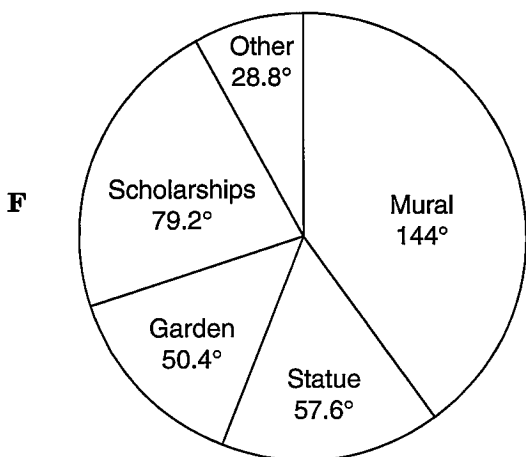

Senior Class Gift

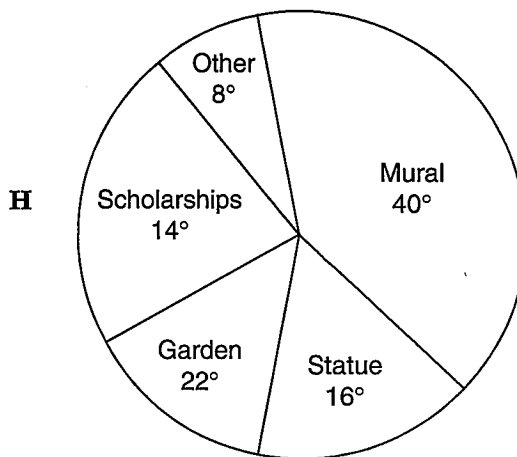

Senior Class Gift

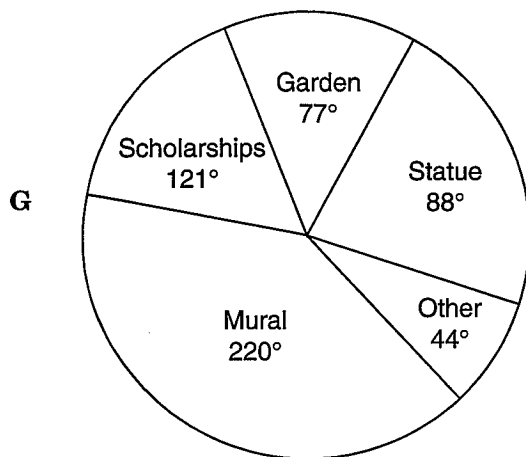

Senior Class Gift

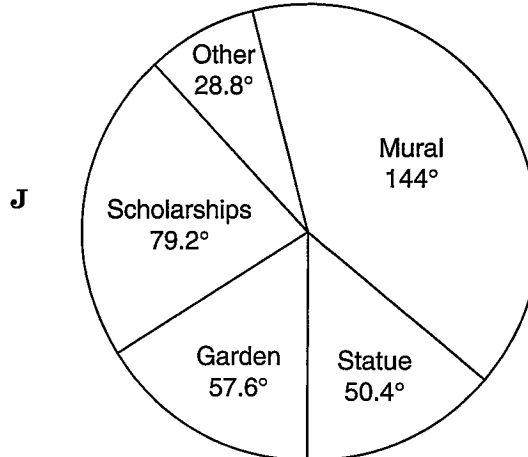

- 17 Which quadratic equation best represents the parabola shown below?

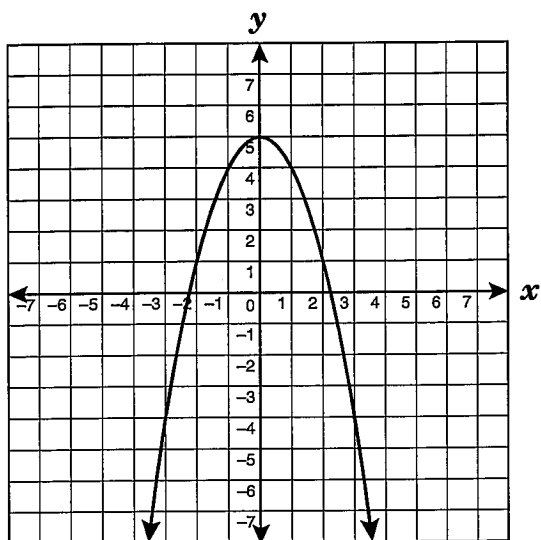

- A $y = x^2 + x + 5$
- B $y = x^2 + 5$
- C $y = -x^2 + 5$
- D $y = -x^2 + x + 5$

- 18 The net of a regular triangular pyramid is shown below. Use the ruler on the Mathematics Chart to measure the dimensions of the pyramid to the nearest tenth of a centimeter.

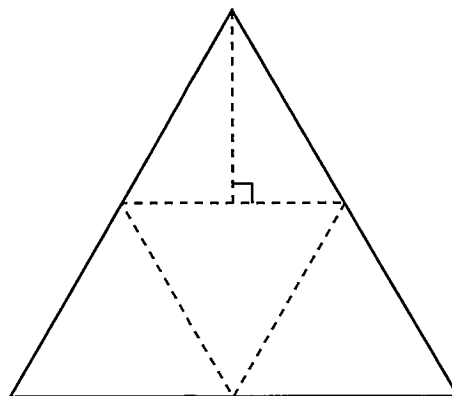

Which of the following best represents the total area of this net?

- F 8 cm^2
- G 16 cm^2
- H 12 cm^2
- J 31 cm^2

- 19 The figure below shows the positions of a surveying crew measuring the distance to a tree across the river.

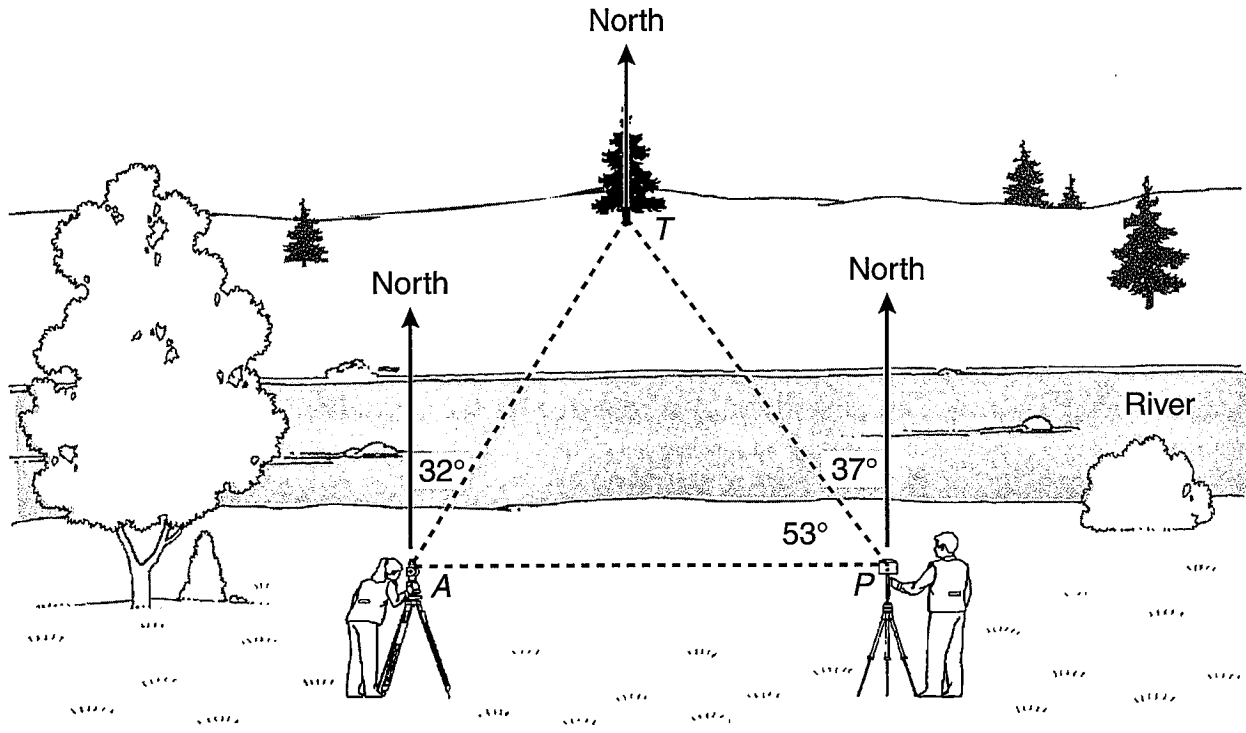

Which of the following best represents the measure of $\angle TAP$?

- A 58°
- B 69°
- C 90°
- D 122°

20 What are the coordinates of the x -intercept of the function graphed below?

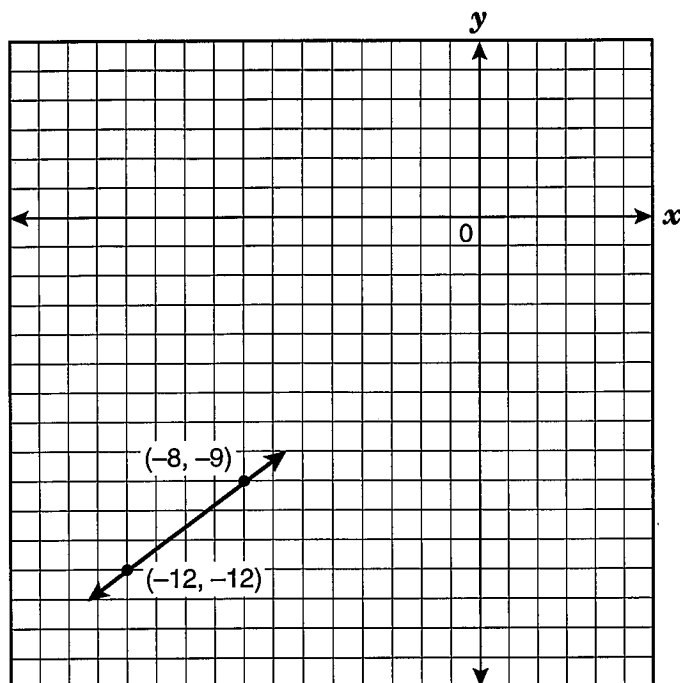

- F $(4, 0)$
- G $(-3, 0)$
- H $(0, 4)$
- J $(0, -3)$

- 21 A large cheese pizza at Palanzio's Pizzeria costs \$6.80 plus \$0.90 for each topping. The cost of a large cheese pizza at Guido's Pizza is \$7.30 plus \$0.65 for each topping. How many toppings need to be added to a large cheese pizza from Palanzio's Pizzeria and Guido's Pizza in order for the pizzas to cost the same, not including tax?

Record your answer and fill in the bubbles on your answer document. Be sure to use the correct place value.

- 22 Which of the following is a sufficient condition to show that a certain equation does not represent a linear function?

- F The graph of the equation has a slope of zero.
- G The graph of the equation has the set of all real numbers as its domain.
- H The graph of the equation has an undefined slope.
- J The graph of the equation has exactly one y -intercept.

- 23 The mass of Earth is close to 5.97×10^{24} kilograms, and the mass of Venus is close to 4.87×10^{24} kilograms. What is the combined mass of both planets?

- A 1.08×10^{25} kg
- B 2.91×10^{49} kg
- C 1.08×10^{48} kg
- D 1.10×10^{24} kg

- 24 The polygon $RSTU$ is shown below.

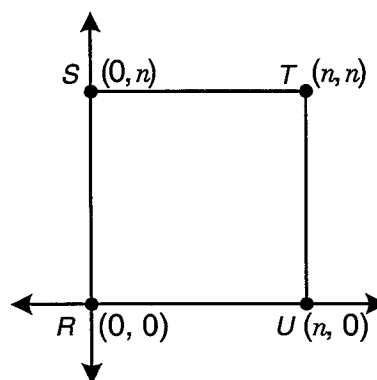

Which expression represents the area of this polygon?

- F $4n^2$
- G $4n$
- H $2n$
- J n^2

- 25 The graph below shows the number of lightbulbs in thousands that the Electric Lightbulb Company sold from 1998 to 2001.

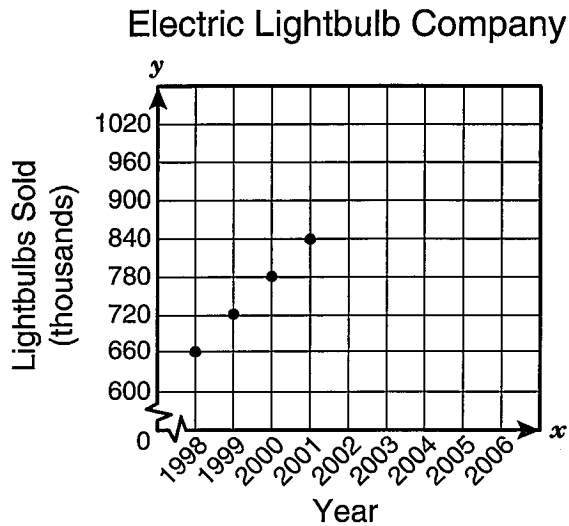

If the trend shown on the graph continues, in what year can the Electric Lightbulb Company first expect to sell more than 1.3 million lightbulbs?

- A 2010
- B 2008
- C 2009
- D 2011

- 26 Brian was 1 out of 25 students who took a practice college entrance exam. No two students scored the same on the exam. If x represents the number of students who scored higher than Brian, which expression represents the number of students who scored lower than Brian?

- F $24 - x$
- G $x - 24$
- H $25 - x$
- J $x - 25$

- 27 A diagonal walkway through a park is 18 meters long. If the park is a square, how long is one of its sides to the nearest tenth of a meter?

- A 9.0 m
- B 12.7 m
- C 18.0 m
- D 25.5 m

- 28 The circle graph below shows the different kinds of garbage collected in the year 2000 according to the Environmental Protection Agency.

Total Garbage Collected,
2000

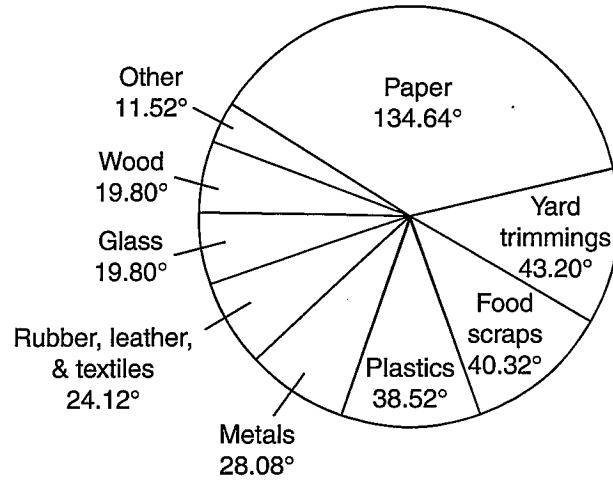

According to this information, which of the following combinations of items is closest to $\frac{2}{3}$ of the garbage collected in the year 2000?

- F Paper, food scraps, plastics, and other
- G Paper, yard trimmings, food scraps, and metals
- H Paper, yard trimmings, plastics, and glass
- J Paper, food scraps, plastics, and wood

29 Which of the following sets of numbers represents the side lengths in units of a right triangle?

- A 5, 3.2, 4.1
- B 3.6, 6, 4.8
- C 4.5, 8, 6.7
- D 8.5, 5.2, 10

30 If $(5\frac{1}{3}, y)$ is a solution to the equation $5x - 4y - 20 = 0$, what is the value of y ?

- F $-11\frac{2}{3}$
- G $8\frac{4}{15}$
- H $\frac{4}{15}$
- J $1\frac{2}{3}$

31 The regular octagon below shows selected positions on a combination lock.

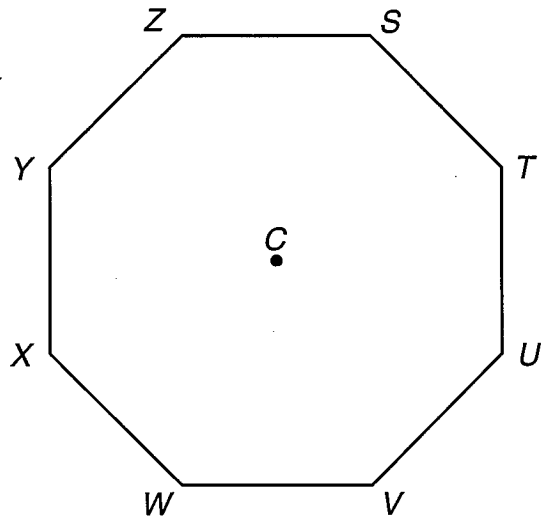

The dial of the lock is turned 90° clockwise and then 45° counterclockwise. Which pair of points can describe the starting and ending points of a marker on the dial of this lock?

- A T to U
- B S to V
- C W to V
- D Z to W

- 32 Mr. Norstam has just released a weather balloon with a diameter of about 3 feet. As the weather balloon rises, it will expand and eventually burst because of the changes in the atmospheric pressure.

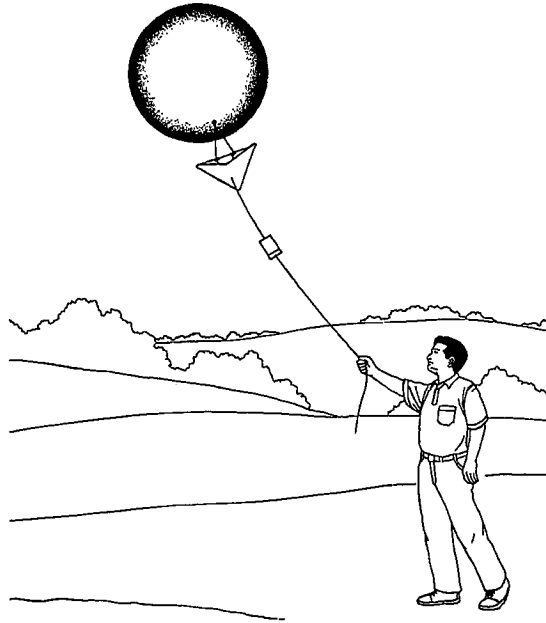

If the weather balloon rises and expands to 1.5 times its diameter before it bursts, what will be its change in volume?

- F The volume will increase to less than 2 times the original volume.
- G The volume will increase to between 2 and 3 times the original volume.
- H The volume will increase to between 3 and 4 times the original volume.
- J The volume will increase to between 4 and 5 times the original volume.

- 33 If the slope of the equation $y = -\frac{3}{5}x + 4$ is changed to $\frac{3}{5}$ and the y -intercept is changed to $(0, -4)$, which statement best describes this situation?

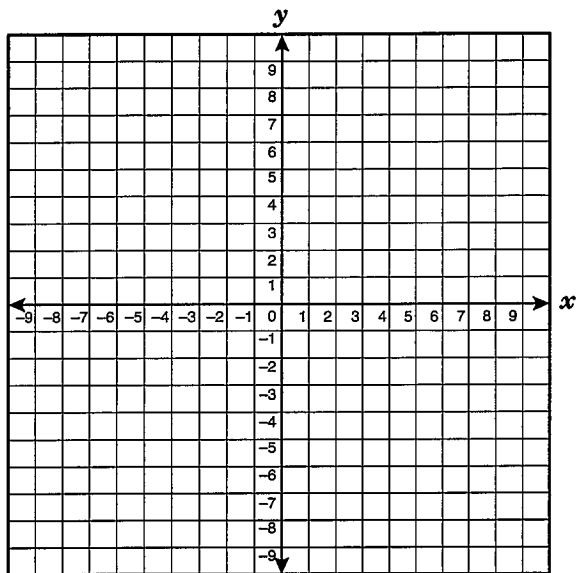

- A The new line is perpendicular to the original line.
 B The new line is parallel to the original line.
 C The new line and the original line have the same y -intercept.
 D The new line and the original line have the same x -intercept.

- 34 Karen, Simone, and Cameron contributed \$64 altogether to pay their phone bill. Karen's contribution was four dollars more than twice as much as Cameron's. Karen's contribution was three times as much as Simone's. What was the amount of Cameron's contribution?

- F \$36
 G \$16
 H \$12
 J Not here

- 35 Mr. Jenkins designed a true-false science exam. The ratio of true answers to false answers is 5:3. Which is closest to the percentage of true answers on Mr. Jenkins's science exam?

- A 53%
 B 60%
 C 38%
 D 63%

- 36 The graph below represents which type of parent function?

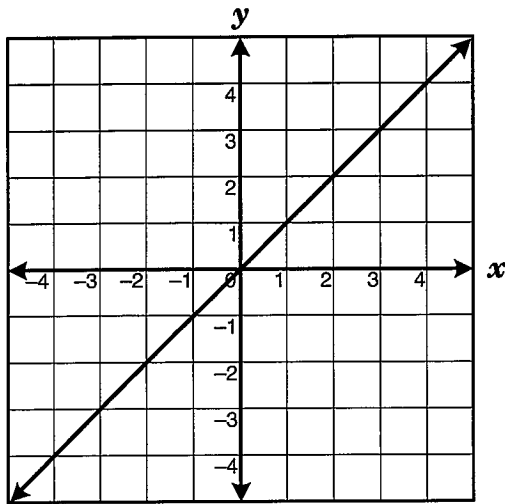

- F Exponential
G Absolute value
H Linear
J Quadratic

- 37 Mitesh is m years old, and his brother Hiren is h years old. Which statement best describes the inequality $m \geq h + 3$?

- A Mitesh is at least 3 times as old as Hiren.
B Mitesh is at least 3 years older than Hiren.
C Hiren is more than 3 years older than Mitesh.
D Hiren is more than 3 times as old as Mitesh.

- 38 Taylor drove down the street to the recreation center. He passed a library, then a playground, and finally a hospital before arriving at the recreation center. The library is 1.7 kilometers from the hospital. The playground is 1.5 kilometers from the recreation center and 0.6 kilometer from the hospital. Which of the following best represents the distance from the library to the recreation center?

- F 3.8 km
G 2.0 km
H 3.2 km
J 2.6 km

- 39 In 2002, people in Laredo, Texas, erected the tallest flagpole in the United States. It can be seen from miles away.

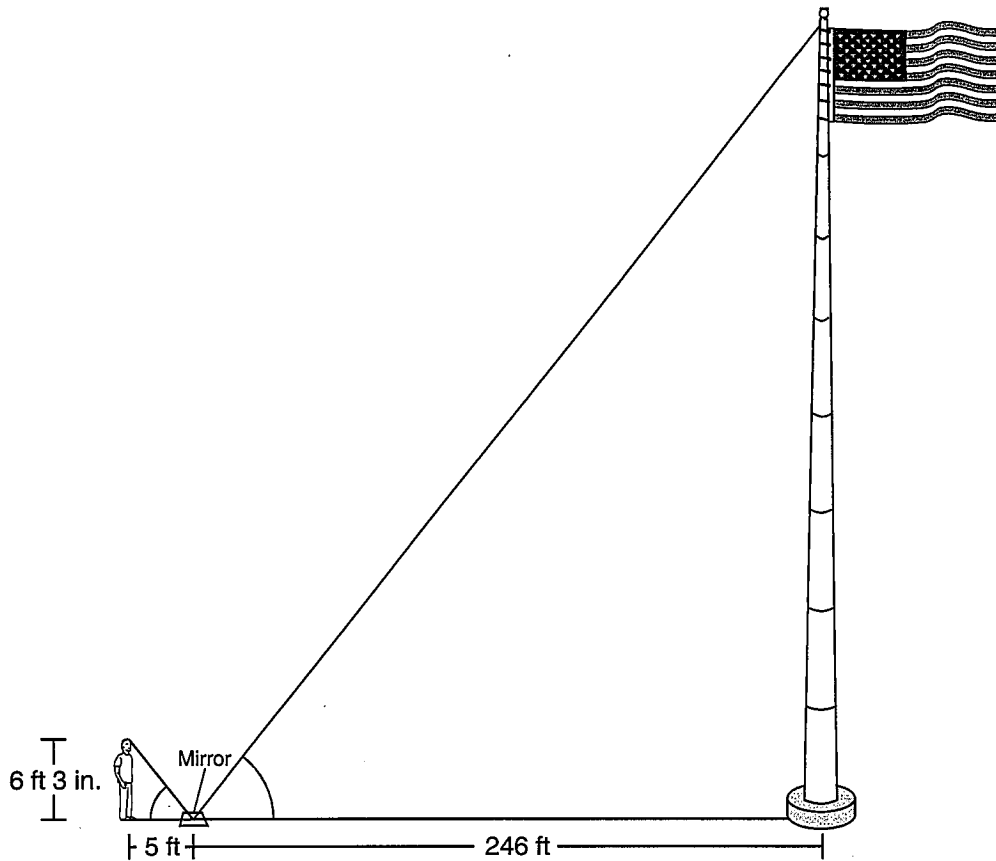

According to the information shown in the drawing, what is the approximate height of the flagpole?
(The drawing is not drawn to scale.)

- A 308 feet
- B 295 feet
- C 205 feet
- D 197 feet

- 40 $\triangle RST$ is a right triangle.

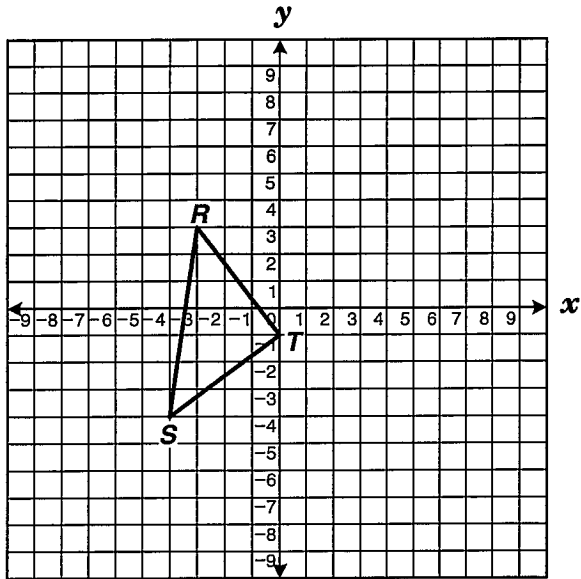

If the equation of the line containing \overline{ST} is $y = \frac{3}{4}x - 1$, which of the following best represents the equation of the line containing \overline{RT} ?

F $y = \frac{4}{3}x - 1$

G $y = -\frac{4}{3}x - 1$

H $y = -\frac{3}{4}x - 1$

J $y = \frac{3}{4}x - 1$

- 41 A salesman at a jewelry store earns a salary of \$295 per week plus a commission of 15% of his weekly sales. If the salesman earned \$936.30 in a week, what was the amount of his sales for the week?

- A \$4275.34
 B \$5947.07
 C \$2115.93
 D \$1371.75

- 42 If y varies directly with x and y is 14 when x is 6, which of the following represents this situation?

F $y = 20x$

G $y = \frac{7}{3}x$

H $y = 8x$

J $y = \frac{3}{7}x$

- 43 Which ordered pairs form the vertices of an isosceles trapezoid?

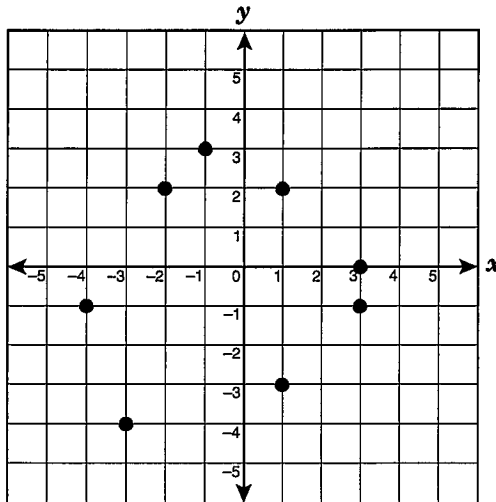

- A (1, 2), (3, -1), (-3, -4), and (-4, -1)
B (1, 2), (3, -1), (-4, -1), and (-2, 2)
C (-1, 3), (3, -1), (-2, 2), and (-4, -1)
D (-1, 3), (-4, -1), (-2, 2), and (3, 0)

-
- 44 Simplify the algebraic expression $\frac{3}{5}(15a^2b - 40ab^2) + \frac{2}{3}(33ab^2 - 6a^2b)$.

- F $5a^2b - 2ab^2$
G $31a^2b - 28ab^2$
H $a^2b + 3ab^2$
J $15a^2b + 18ab^2$

45 Look at the diagram below.

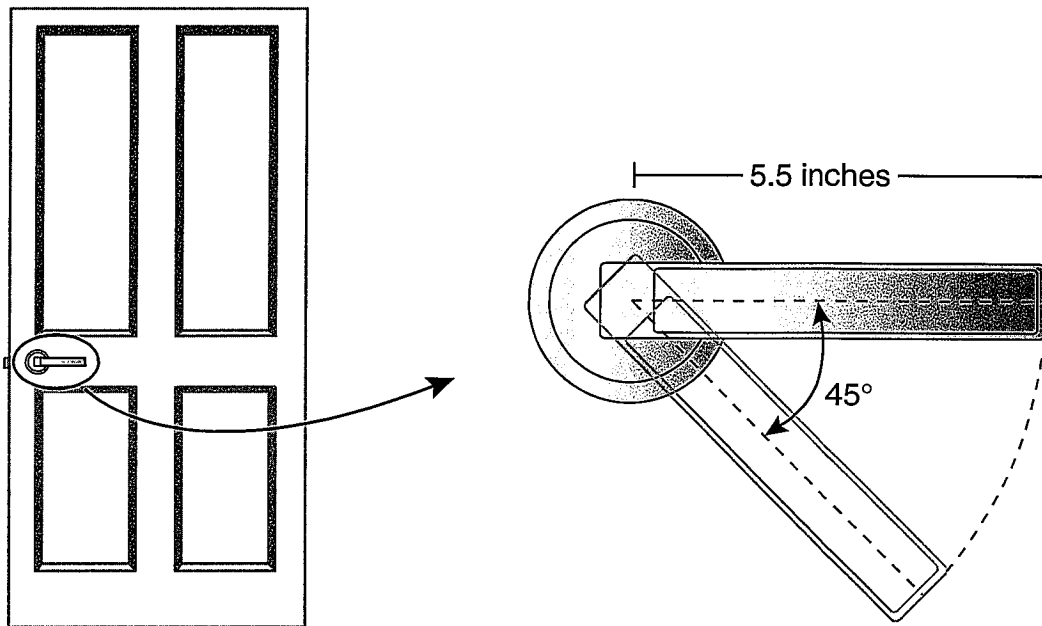

When the door handle is pushed down to open the door, it makes a 45° angle with its former position. What is the approximate arc length of the path traveled by the outside end of the door handle when the handle is pushed down?

- A 34.56 in.
- B 11.88 in.
- C 4.32 in.
- D 2.16 in.

- 46 If the perimeter of the equilateral triangle shown below is 37 centimeters, what is the approximate area of the triangle?

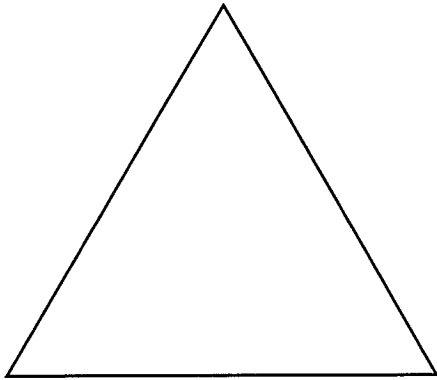

- F 132 cm^2
- G 54 cm^2
- H 33 cm^2
- J 66 cm^2

- 47 Which of the following 3-dimensional figures is made from a set of points in space that are equidistant from a fixed point?

- A Cylinder
- B Sphere
- C Cube
- D Tetrahedron

- 48 Thalia played a word game in which she had a minute to create 5- and 6-letter words from a given word. The given word was *wonderful*. Thalia scored 7 points for each 5-letter word she created and 15 points for each 6-letter word she created. Which of the following is not a possible value for the total points Thalia scored?

- F 37
- G 46
- H 58
- J 59

- 49 A physical education class had 20 students. The table below shows the students' grades and the number of days each student was absent.

Grade Compared with Attendance

Grade	Number of Days Absent
A	0, 3, 2, 2, 1, 1, 4
Less than A	4, 5, 9, 7, 6, 3, 5, 3, 6, 5, 8, 7, 9

Which conclusion about the students in this class is true?

- A Each student who earned a grade of A was absent fewer than 4 days.
- B Each student who was absent fewer than 4 days earned a grade of A.
- C Each student who was absent more than 2 days did not earn a grade of A.
- D Each student who did not earn a grade of A was absent more than 2 days.

-
- 50 Look at the figure shown below.

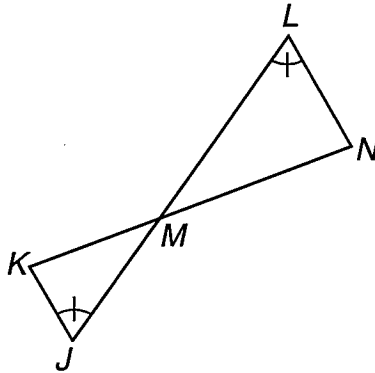

If $\triangle MKJ \sim \triangle MNL$, which of the following must be true?

- F $\angle JKM \cong \angle NLM$, because corresponding angles of similar triangles are congruent.
- G $\frac{MK}{MN} = \frac{KJ}{NL}$, because the ratios of the lengths of corresponding sides of similar triangles are equal.
- H $\frac{KJ}{LN} = \frac{ML}{MK}$, because the ratios of the lengths of corresponding sides of similar triangles are equal.
- J $\angle KJM \cong \angle MNL$, because corresponding angles of similar triangles are congruent.

51 Look at the equations shown below.

$$y = \frac{4}{5}x^2 + 3, \quad y = \frac{4}{5}x^2, \quad y = \frac{4}{5}x^2 - 5, \quad y = \frac{4}{5}x^2 + \frac{3}{5}$$

Which of the following statements is true for the graphs of all the equations given?

- A The graphs are congruent and open downward.
- B The graphs open upward and are symmetrical about the y -axis.
- C The graphs are congruent and are listed from narrowest to widest.
- D The graphs open downward and are symmetrical about the y -axis.

52 An oyster provides approximately 17 calories, and a shrimp provides approximately 26 calories. Jay wants to consume no more than 300 calories eating oysters and shrimp. Which inequality best represents the number of oysters, x , and the number of shrimp, y , that Jay can eat and stay within this limit?

- F $(17 + 26)(x + y) > 300$
- G $(17 + x) + (26 + y) > 300$
- H $(17 + 26)(x + y) \leq 300$
- J $17x + 26y \leq 300$

53 Which of the following polynomial equations best represents this graph?

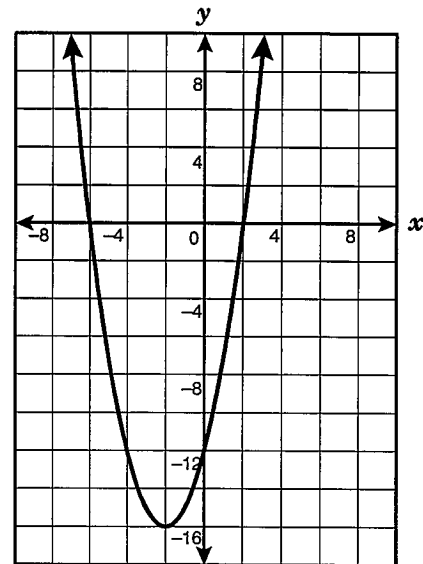

- A $(x + 6)(x - 2) = y$
- B $(x - 2)(x - 16) = y$
- C $(x - 6)(x + 2) = y$
- D $(x + 2)(x + 16) = y$

54 Look at the figures and the table below.

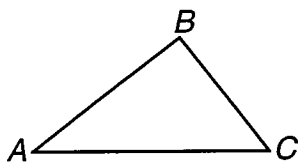

Stage 1

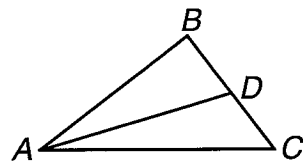

Stage 2

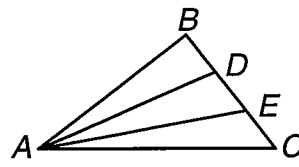

Stage 3

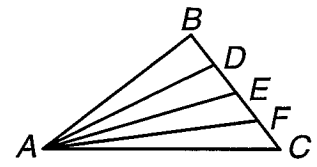

Stage 4

Stage	Number of Triangles
1	1
2	3
3	6
4	10

How many triangles will the n th stage contain?

F $2^n - 1$

G $\frac{n^2 + n}{2}$

H $2n - 1$

J $\frac{n^2 + 2}{2}$

55 On a certain math problem, Cynthia mistakenly divided a number by 4 and then subtracted 24 and got 12 for her answer. After reading the problem again, she realized that she should have subtracted 24 before dividing by 4. What was the correct answer?

- A -48
- B -28
- C 30
- D 144

56 The table below shows the relationship between x and y .

x	y
-1	-1
0	1
1	3
2	17

Which function best represents the relationship between the quantities in the table?

- F $y = 2x + 1$
- G $y = 2x^3 + 1$
- H $y = 2x^2 - 3$
- J $y = 2x^2 + 4x + 1$

57 The midpoint of the diagonals of rectangle $PTQW$ is $(-0.5, 1)$. The coordinates of P are $(-3.5, 6)$. What are the coordinates of Q ?

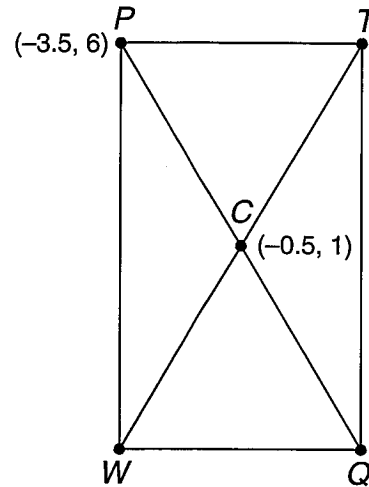

- A $(-2, 3.5)$
- B $(-6.5, 11)$
- C $(-1.5, 2.5)$
- D $(2.5, -4)$

- 58 The graph below shows the number of pies and the number of cakes that the students in the art club need to sell at the school bake sale in order to raise \$150.

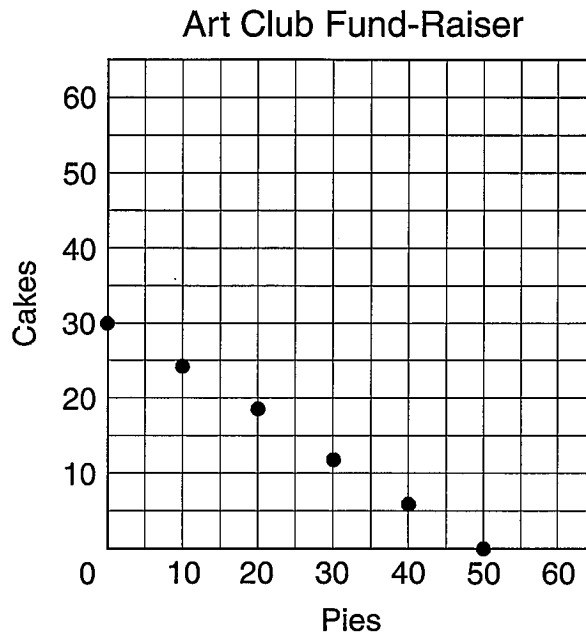

Which of the following represents the maximum number of cakes the art club could sell to raise exactly \$150?

- F 40
- G 25
- H 50
- J 30

-
- 59 Ms. Collins's car traveled between 25 and 29 miles per gallon of gasoline on a recent road trip. If the road trip was 614 miles, which could be the number of gallons of gasoline that Ms. Collins used during this road trip?

- A 23 gal
- B 29 gal
- C 21 gal
- D 25 gal

- 60 The drawing shows the top view of a structure built with cubes as well as the number of cubes in each column of the structure.

4	3	2	Right
2	3	1	
1	2	1	
Front			

Which 3-dimensional view represents the same structure?

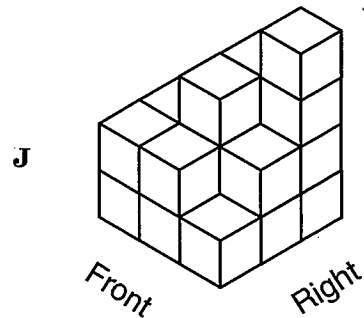
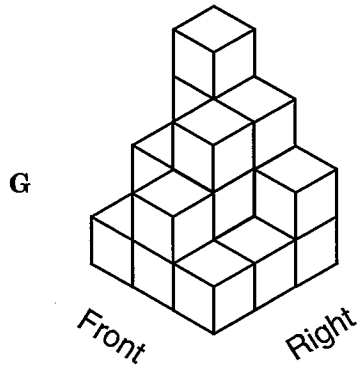
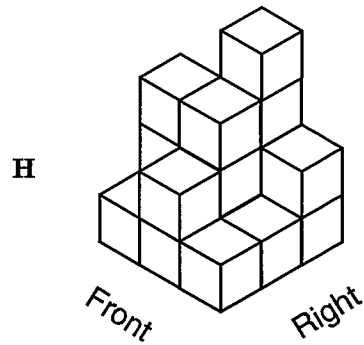
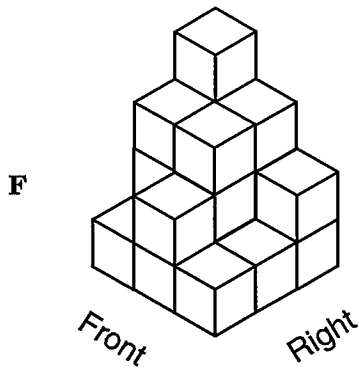

BE SURE YOU HAVE RECORDED ALL OF YOUR ANSWERS
ON THE ANSWER DOCUMENT.



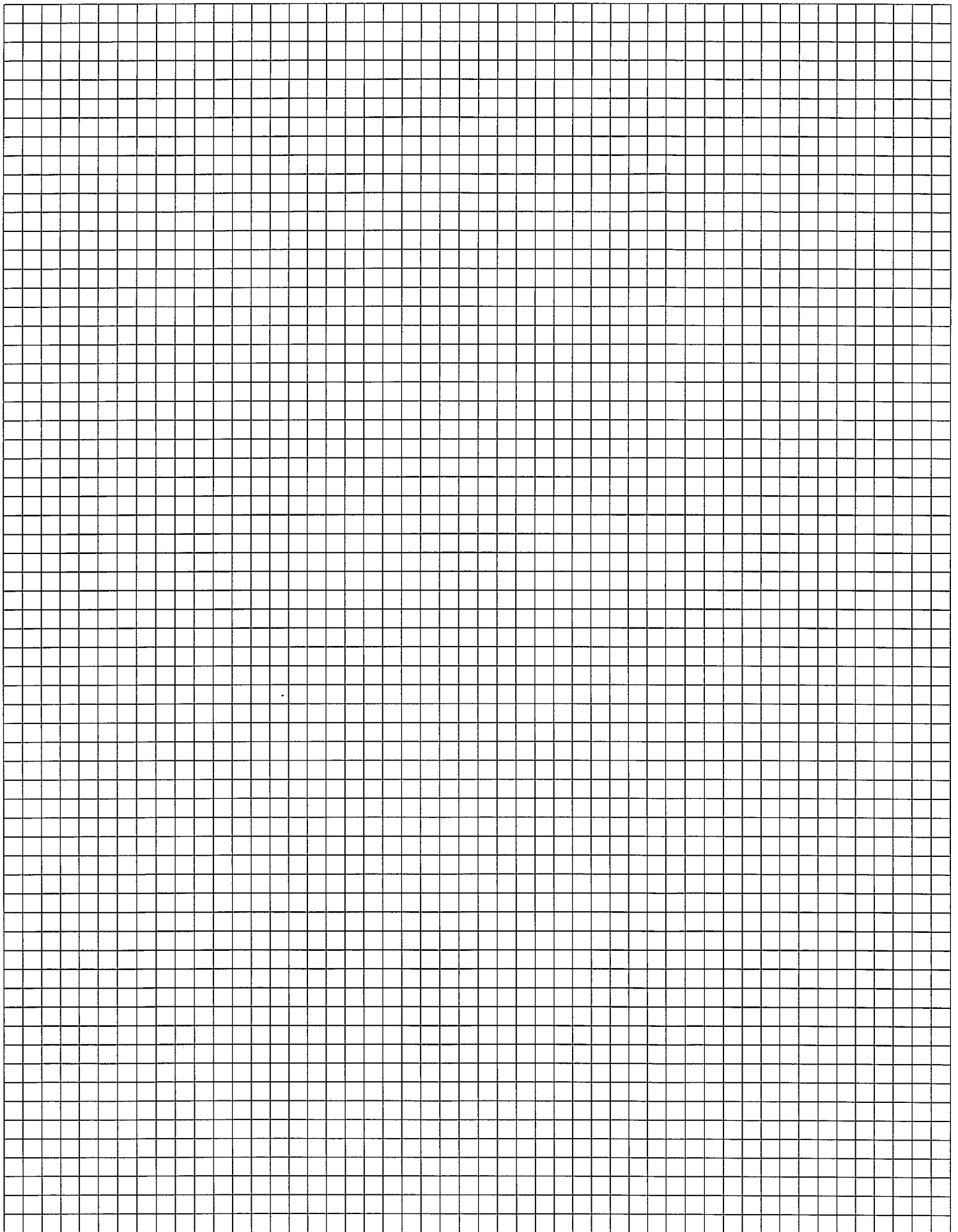

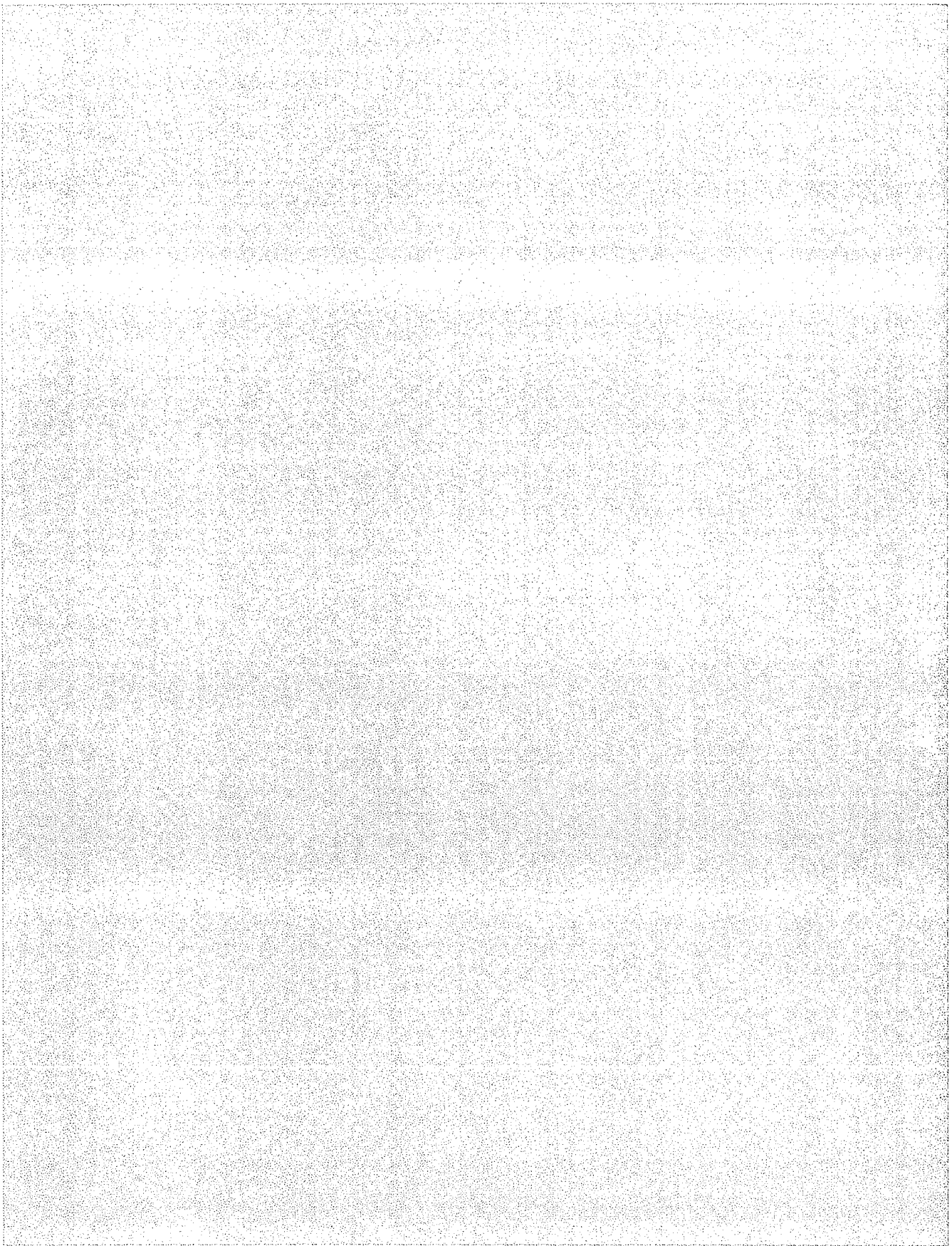

SCIENCE



FORMULA CHART

Density = $\frac{\text{mass}}{\text{volume}}$	$D = \frac{m}{v}$
$\left(\begin{array}{c} \text{heat gained} \\ \text{or lost} \end{array} \right) = \left(\begin{array}{c} \text{mass in} \\ \text{grams} \end{array} \right) \left(\begin{array}{c} \text{change in} \\ \text{temperature} \end{array} \right) \left(\begin{array}{c} \text{specific} \\ \text{heat} \end{array} \right)$	$Q = (m)(\Delta T)(C_p)$
Speed = $\frac{\text{distance traveled}}{\text{time}}$	$v = \frac{d}{t}$
Acceleration = $\frac{\text{final velocity} - \text{initial velocity}}{\text{change in time}}$	$a = \frac{v_f - v_i}{\Delta t}$
Momentum = mass \times velocity	$p = mv$
Force = mass \times acceleration	$F = ma$
Work = force \times distance	$W = Fd$
Power = $\frac{\text{work}}{\text{time}}$	$P = \frac{W}{t}$
% efficiency = $\frac{\text{work output}}{\text{work input}} \times 100$	$\% = \frac{W_o}{W_i} \times 100$
Kinetic energy = $\frac{1}{2} (\text{mass} \times \text{velocity}^2)$	$KE = \frac{mv^2}{2}$
Gravitational potential energy = mass \times acceleration due to gravity \times height	$PE = mgh$
Energy = mass \times (speed of light) ²	$E = mc^2$
Velocity of a wave = frequency \times wavelength	$v = f\lambda$
Current = $\frac{\text{voltage}}{\text{resistance}}$	$I = \frac{V}{R}$
Electrical power = voltage \times current	$P = VI$
Electrical energy = power \times time	$E = Pt$

Constants/Conversions		
$g = \text{acceleration due to gravity} = 9.8 \text{ m/s}^2$		
$c = \text{speed of light} = 3 \times 10^8 \text{ m/s}$		
speed of sound = 343 m/s at sea level and 20°C		
$1 \text{ cm}^3 = 1 \text{ mL}$		
1 wave cycle/second = 1 hertz (Hz)		
1 calorie (cal) = 4.18 joules		
1000 calories (cal) = 1 Calorie (Cal) = 1 kilocalorie (kcal)		
newton (N) = kg m/s^2		
joule (J) = Nm		
watt (W) = J/s = Nm/s		
volt (V)	ampere (A)	ohm (Ω)

Periodic Table of the Elements

Atomic number — 14
 Symbol — **Si**
 Atomic mass — 28.086
 Silicon — Name

Group	1	2											13	14	15	16	17	18																																																																																													
	IA	IIA											IIIA	IVA	VA	VIA	VIIA	VIIIA																																																																																													
1	1 H 1.008 Hydrogen	2 He 4.0026 Helium											5 B 10.81 Boron	6 C 12.011 Carbon	7 N 14.007 Nitrogen	8 O 15.999 Oxygen	9 F 18.998 Fluorine	10 Ne 20.179 Neon																																																																																													
2	3 Li 6.941 Lithium	4 Be 9.012 Beryllium											13 Al 26.982 Aluminum	14 Si 28.086 Silicon	15 P 30.974 Phosphorus	16 S 32.066 Sulfur	17 Cl 35.453 Chlorine	18 Ar 39.948 Argon																																																																																													
3	11 Na 22.990 Sodium	12 Mg 24.305 Magnesium											31 Ga 69.72 Gallium	32 Ge 72.61 Germanium	33 As 74.922 Arsenic	34 Se 78.96 Selenium	35 Br 79.904 Bromine	36 Kr 83.80 Krypton																																																																																													
4	19 K 39.098 Potassium	20 Ca 40.08 Calcium											49 In 114.82 Indium	50 Sn 118.71 Tin	51 Sb 121.763 Antimony	52 Te 127.60 Tellurium	53 I 126.904 Iodine	54 Xe 131.29 Xenon																																																																																													
5	37 Rb 85.468 Rubidium	38 Sr 87.62 Strontium											81 Tl 204.383 Thallium	82 Pb 207.2 Lead	83 Bi 208.980 Bismuth	84 Po (209) Polonium	85 At (210) Astatine	86 Rn (222) Radon																																																																																													
6	55 Cs 132.905 Cesium	56 Ba 137.33 Barium											111 Ag 107.868 Silver	112 Cd 112.41 Cadmium	113 In 114.82 Indium	114 Sn 118.71 Tin	115 Sb 121.763 Antimony	116 Te 127.60 Tellurium	117 I 126.904 Iodine	118 Xe 131.29 Xenon																																																																																											
7	87 Fr (223) Francium	88 Ra 226.025 Radium											80 Hg 200.59 Mercury	81 Tl 204.383 Thallium	82 Pb 207.2 Lead	83 Bi 208.980 Bismuth	84 Po (209) Polonium	85 At (210) Astatine	86 Rn (222) Radon																																																																																												
			<table border="1" style="width: 100%; border-collapse: collapse; text-align: center;"> <thead> <tr> <th style="width: 5%;">8</th> <th style="width: 5%;">9</th> <th style="width: 5%;">10</th> </tr> <tr> <th>VIII</th> <th>VIII</th> <th>VIII</th> </tr> </thead> <tbody> <tr> <td>26 Fe 55.847 Iron</td> <td>27 Co 58.933 Cobalt</td> <td>28 Ni 58.69 Nickel</td> </tr> <tr> <td>44 Ru 101.07 Ruthenium</td> <td>45 Rh 102.906 Rhodium</td> <td>46 Pd 106.42 Palladium</td> </tr> <tr> <td>76 Os 190.23 Osmium</td> <td>77 Ir 192.22 Iridium</td> <td>78 Pt 195.08 Platinum</td> </tr> <tr> <td>108 Hs (265) Hassium</td> <td>109 Mt (266) Meitnerium</td> <td>110 Ds (269) Darmstadtium</td> </tr> </tbody> </table>										8	9	10	VIII	VIII	VIII	26 Fe 55.847 Iron	27 Co 58.933 Cobalt	28 Ni 58.69 Nickel	44 Ru 101.07 Ruthenium	45 Rh 102.906 Rhodium	46 Pd 106.42 Palladium	76 Os 190.23 Osmium	77 Ir 192.22 Iridium	78 Pt 195.08 Platinum	108 Hs (265) Hassium	109 Mt (266) Meitnerium	110 Ds (269) Darmstadtium																																																																																	
8	9	10																																																																																																													
VIII	VIII	VIII																																																																																																													
26 Fe 55.847 Iron	27 Co 58.933 Cobalt	28 Ni 58.69 Nickel																																																																																																													
44 Ru 101.07 Ruthenium	45 Rh 102.906 Rhodium	46 Pd 106.42 Palladium																																																																																																													
76 Os 190.23 Osmium	77 Ir 192.22 Iridium	78 Pt 195.08 Platinum																																																																																																													
108 Hs (265) Hassium	109 Mt (266) Meitnerium	110 Ds (269) Darmstadtium																																																																																																													
			<table border="1" style="width: 100%; border-collapse: collapse; text-align: center;"> <thead> <tr> <th style="width: 5%;">7</th> <th style="width: 5%;">8</th> <th style="width: 5%;">9</th> <th style="width: 5%;">10</th> <th style="width: 5%;">11</th> <th style="width: 5%;">12</th> </tr> <tr> <th>VIIIB</th> <th>VIIIB</th> <th>VIIIB</th> <th>VIIIB</th> <th>IB</th> <th>IIB</th> </tr> </thead> <tbody> <tr> <td>25 Mn 54.938 Manganese</td> <td>26 Fe 55.847 Iron</td> <td>27 Co 58.933 Cobalt</td> <td>28 Ni 58.69 Nickel</td> <td>29 Cu 63.546 Copper</td> <td>30 Zn 65.39 Zinc</td> </tr> <tr> <td>43 Tc (98) Technetium</td> <td>44 Ru 101.07 Ruthenium</td> <td>45 Rh 102.906 Rhodium</td> <td>46 Pd 106.42 Palladium</td> <td>47 Ag 107.868 Silver</td> <td>48 Cd 112.41 Cadmium</td> </tr> <tr> <td>75 Re 186.207 Rhenium</td> <td>76 Os 190.23 Osmium</td> <td>77 Ir 192.22 Iridium</td> <td>78 Pt 195.08 Platinum</td> <td>79 Au 196.967 Gold</td> <td>80 Hg 200.59 Mercury</td> </tr> <tr> <td>107 Bh (262) Bohrium</td> <td>108 Hs (265) Hassium</td> <td>109 Mt (266) Meitnerium</td> <td>110 Ds (269) Darmstadtium</td> <td>111 Rg (271) Roentgenium</td> <td>112 Cn (285) Copernicium</td> </tr> </tbody> </table>										7	8	9	10	11	12	VIIIB	VIIIB	VIIIB	VIIIB	IB	IIB	25 Mn 54.938 Manganese	26 Fe 55.847 Iron	27 Co 58.933 Cobalt	28 Ni 58.69 Nickel	29 Cu 63.546 Copper	30 Zn 65.39 Zinc	43 Tc (98) Technetium	44 Ru 101.07 Ruthenium	45 Rh 102.906 Rhodium	46 Pd 106.42 Palladium	47 Ag 107.868 Silver	48 Cd 112.41 Cadmium	75 Re 186.207 Rhenium	76 Os 190.23 Osmium	77 Ir 192.22 Iridium	78 Pt 195.08 Platinum	79 Au 196.967 Gold	80 Hg 200.59 Mercury	107 Bh (262) Bohrium	108 Hs (265) Hassium	109 Mt (266) Meitnerium	110 Ds (269) Darmstadtium	111 Rg (271) Roentgenium	112 Cn (285) Copernicium																																																															
7	8	9	10	11	12																																																																																																										
VIIIB	VIIIB	VIIIB	VIIIB	IB	IIB																																																																																																										
25 Mn 54.938 Manganese	26 Fe 55.847 Iron	27 Co 58.933 Cobalt	28 Ni 58.69 Nickel	29 Cu 63.546 Copper	30 Zn 65.39 Zinc																																																																																																										
43 Tc (98) Technetium	44 Ru 101.07 Ruthenium	45 Rh 102.906 Rhodium	46 Pd 106.42 Palladium	47 Ag 107.868 Silver	48 Cd 112.41 Cadmium																																																																																																										
75 Re 186.207 Rhenium	76 Os 190.23 Osmium	77 Ir 192.22 Iridium	78 Pt 195.08 Platinum	79 Au 196.967 Gold	80 Hg 200.59 Mercury																																																																																																										
107 Bh (262) Bohrium	108 Hs (265) Hassium	109 Mt (266) Meitnerium	110 Ds (269) Darmstadtium	111 Rg (271) Roentgenium	112 Cn (285) Copernicium																																																																																																										
			<table border="1" style="width: 100%; border-collapse: collapse; text-align: center;"> <thead> <tr> <th style="width: 5%;">3</th> <th style="width: 5%;">4</th> <th style="width: 5%;">5</th> <th style="width: 5%;">6</th> <th style="width: 5%;">7</th> <th style="width: 5%;">8</th> <th style="width: 5%;">9</th> <th style="width: 5%;">10</th> <th style="width: 5%;">11</th> <th style="width: 5%;">12</th> <th style="width: 5%;">13</th> <th style="width: 5%;">14</th> <th style="width: 5%;">15</th> <th style="width: 5%;">16</th> <th style="width: 5%;">17</th> <th style="width: 5%;">18</th> </tr> <tr> <th>IIIB</th> <th>IVB</th> <th>VB</th> <th>VIB</th> <th>VIIIB</th> <th>VIIIB</th> <th>VIIIB</th> <th>VIIIB</th> <th>IB</th> <th>IIB</th> <th>IIIA</th> <th>IVA</th> <th>VA</th> <th>VIA</th> <th>VIIA</th> <th>VIIIA</th> </tr> </thead> <tbody> <tr> <td>21 Sc 44.956 Scandium</td> <td>22 Ti 47.88 Titanium</td> <td>23 V 50.942 Vanadium</td> <td>24 Cr 51.996 Chromium</td> <td>25 Mn 54.938 Manganese</td> <td>26 Fe 55.847 Iron</td> <td>27 Co 58.933 Cobalt</td> <td>28 Ni 58.69 Nickel</td> <td>29 Cu 63.546 Copper</td> <td>30 Zn 65.39 Zinc</td> <td>31 Ga 69.72 Gallium</td> <td>32 Ge 72.61 Germanium</td> <td>33 As 74.922 Arsenic</td> <td>34 Se 78.96 Selenium</td> <td>35 Br 79.904 Bromine</td> <td>36 Kr 83.80 Krypton</td> </tr> <tr> <td>39 Y 88.906 Yttrium</td> <td>40 Zr 91.224 Zirconium</td> <td>41 Nb 92.906 Niobium</td> <td>42 Mo 95.94 Molybdenum</td> <td>43 Tc (98) Technetium</td> <td>44 Ru 101.07 Ruthenium</td> <td>45 Rh 102.906 Rhodium</td> <td>46 Pd 106.42 Palladium</td> <td>47 Ag 107.868 Silver</td> <td>48 Cd 112.41 Cadmium</td> <td>49 In 114.82 Indium</td> <td>50 Sn 118.71 Tin</td> <td>51 Sb 121.763 Antimony</td> <td>52 Te 127.60 Tellurium</td> <td>53 I 126.904 Iodine</td> <td>54 Xe 131.29 Xenon</td> </tr> <tr> <td>57 La 138.906 Lanthanum</td> <td>58 Ce 137.33 Cerium</td> <td>59 Pr 140.908 Praseodymium</td> <td>60 Nd 144.24 Neodymium</td> <td>61 Pm (145) Promethium</td> <td>62 Sm 150.36 Samarium</td> <td>63 Eu 151.97 Europium</td> <td>64 Gd 157.25 Gadolinium</td> <td>65 Tb 158.925 Terbium</td> <td>66 Dy 162.50 Dysprosium</td> <td>67 Ho 164.930 Holmium</td> <td>68 Er 167.26 Erbium</td> <td>69 Tm 168.934 Thulium</td> <td>70 Yb 173.04 Ytterbium</td> <td>71 Lu 174.967 Lutetium</td> </tr> <tr> <td>89 Ac 227.028 Actinium</td> <td>90 Th 232.038 Thorium</td> <td>91 Pa 231.036 Protactinium</td> <td>92 U 238.029 Uranium</td> <td>93 Np 237.048 Neptunium</td> <td>94 Pu (244) Plutonium</td> <td>95 Am (243) Americium</td> <td>96 Cm (247) Curium</td> <td>97 Bk (247) Berkelium</td> <td>98 Cf (251) Californium</td> <td>99 Es (252) Einsteinium</td> <td>100 Fm (257) Fermium</td> <td>101 Md (258) Mendelevium</td> <td>102 No (259) Nobelium</td> <td>103 Lr (262) Lawrencium</td> </tr> </tbody> </table>										3	4	5	6	7	8	9	10	11	12	13	14	15	16	17	18	IIIB	IVB	VB	VIB	VIIIB	VIIIB	VIIIB	VIIIB	IB	IIB	IIIA	IVA	VA	VIA	VIIA	VIIIA	21 Sc 44.956 Scandium	22 Ti 47.88 Titanium	23 V 50.942 Vanadium	24 Cr 51.996 Chromium	25 Mn 54.938 Manganese	26 Fe 55.847 Iron	27 Co 58.933 Cobalt	28 Ni 58.69 Nickel	29 Cu 63.546 Copper	30 Zn 65.39 Zinc	31 Ga 69.72 Gallium	32 Ge 72.61 Germanium	33 As 74.922 Arsenic	34 Se 78.96 Selenium	35 Br 79.904 Bromine	36 Kr 83.80 Krypton	39 Y 88.906 Yttrium	40 Zr 91.224 Zirconium	41 Nb 92.906 Niobium	42 Mo 95.94 Molybdenum	43 Tc (98) Technetium	44 Ru 101.07 Ruthenium	45 Rh 102.906 Rhodium	46 Pd 106.42 Palladium	47 Ag 107.868 Silver	48 Cd 112.41 Cadmium	49 In 114.82 Indium	50 Sn 118.71 Tin	51 Sb 121.763 Antimony	52 Te 127.60 Tellurium	53 I 126.904 Iodine	54 Xe 131.29 Xenon	57 La 138.906 Lanthanum	58 Ce 137.33 Cerium	59 Pr 140.908 Praseodymium	60 Nd 144.24 Neodymium	61 Pm (145) Promethium	62 Sm 150.36 Samarium	63 Eu 151.97 Europium	64 Gd 157.25 Gadolinium	65 Tb 158.925 Terbium	66 Dy 162.50 Dysprosium	67 Ho 164.930 Holmium	68 Er 167.26 Erbium	69 Tm 168.934 Thulium	70 Yb 173.04 Ytterbium	71 Lu 174.967 Lutetium	89 Ac 227.028 Actinium	90 Th 232.038 Thorium	91 Pa 231.036 Protactinium	92 U 238.029 Uranium	93 Np 237.048 Neptunium	94 Pu (244) Plutonium	95 Am (243) Americium	96 Cm (247) Curium	97 Bk (247) Berkelium	98 Cf (251) Californium	99 Es (252) Einsteinium	100 Fm (257) Fermium	101 Md (258) Mendelevium	102 No (259) Nobelium	103 Lr (262) Lawrencium					
3	4	5	6	7	8	9	10	11	12	13	14	15	16	17	18																																																																																																
IIIB	IVB	VB	VIB	VIIIB	VIIIB	VIIIB	VIIIB	IB	IIB	IIIA	IVA	VA	VIA	VIIA	VIIIA																																																																																																
21 Sc 44.956 Scandium	22 Ti 47.88 Titanium	23 V 50.942 Vanadium	24 Cr 51.996 Chromium	25 Mn 54.938 Manganese	26 Fe 55.847 Iron	27 Co 58.933 Cobalt	28 Ni 58.69 Nickel	29 Cu 63.546 Copper	30 Zn 65.39 Zinc	31 Ga 69.72 Gallium	32 Ge 72.61 Germanium	33 As 74.922 Arsenic	34 Se 78.96 Selenium	35 Br 79.904 Bromine	36 Kr 83.80 Krypton																																																																																																
39 Y 88.906 Yttrium	40 Zr 91.224 Zirconium	41 Nb 92.906 Niobium	42 Mo 95.94 Molybdenum	43 Tc (98) Technetium	44 Ru 101.07 Ruthenium	45 Rh 102.906 Rhodium	46 Pd 106.42 Palladium	47 Ag 107.868 Silver	48 Cd 112.41 Cadmium	49 In 114.82 Indium	50 Sn 118.71 Tin	51 Sb 121.763 Antimony	52 Te 127.60 Tellurium	53 I 126.904 Iodine	54 Xe 131.29 Xenon																																																																																																
57 La 138.906 Lanthanum	58 Ce 137.33 Cerium	59 Pr 140.908 Praseodymium	60 Nd 144.24 Neodymium	61 Pm (145) Promethium	62 Sm 150.36 Samarium	63 Eu 151.97 Europium	64 Gd 157.25 Gadolinium	65 Tb 158.925 Terbium	66 Dy 162.50 Dysprosium	67 Ho 164.930 Holmium	68 Er 167.26 Erbium	69 Tm 168.934 Thulium	70 Yb 173.04 Ytterbium	71 Lu 174.967 Lutetium																																																																																																	
89 Ac 227.028 Actinium	90 Th 232.038 Thorium	91 Pa 231.036 Protactinium	92 U 238.029 Uranium	93 Np 237.048 Neptunium	94 Pu (244) Plutonium	95 Am (243) Americium	96 Cm (247) Curium	97 Bk (247) Berkelium	98 Cf (251) Californium	99 Es (252) Einsteinium	100 Fm (257) Fermium	101 Md (258) Mendelevium	102 No (259) Nobelium	103 Lr (262) Lawrencium																																																																																																	

Mass numbers in parentheses are those of the most stable or most common isotope.

Lanthanide Series

Actinide Series



DIRECTIONS

Read each question and choose the best answer. Then fill in the correct answer on your answer document.

SAMPLE A

When a 10% hydrochloric acid solution is heated in an open test tube, the test tube should always be pointed —

- A so bubbles are visible
- B at a 180° angle from the flame
- C toward a ventilated area
- D away from nearby people

SAMPLE B

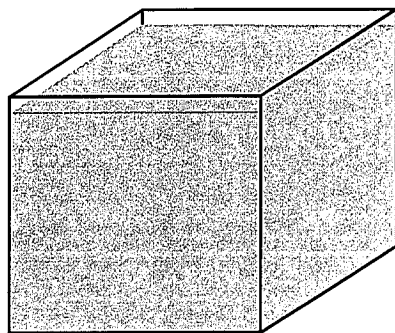

Mass = 40 g

Volume = 20 mL

The picture shows a cube that contains 20 mL of a solution. The solution has a mass of 40 grams. What is the density in g/mL of this solution? Record and bubble in your answer on the answer document.



Independent Project

WHAT TIME OF DAY ARE YOU MOST ALERT?

Assumption: The ability to sort playing cards is an indication of alertness.

Procedure:

1. Shuffle a deck of playing cards four times
2. Time how long it takes to sort the cards into the four suits
3. Repeat the activity at the same times for five days

Data

Time of Day	Average Sorting Time (s)
8:00 A.M.	130
12:00 NOON	105
4:00 P.M.	122
8:00 P.M.	127

- 1 Which of the following conclusions is supported by these data?
- A Alertness is directly related to level of distraction.
 - B Shuffling methods can affect alertness.
 - C Alertness levels vary during the day.
 - D Long periods of rest improve alertness.

- 2 A study shows that 40% to 100% of raw poultry is contaminated by disease-causing bacteria. Which of the following activities provides people the best protection from these bacteria?

- F Rinsing dishes thoroughly
- G Eating a balanced diet daily
- H Visiting a doctor regularly
- J Cooking foods properly

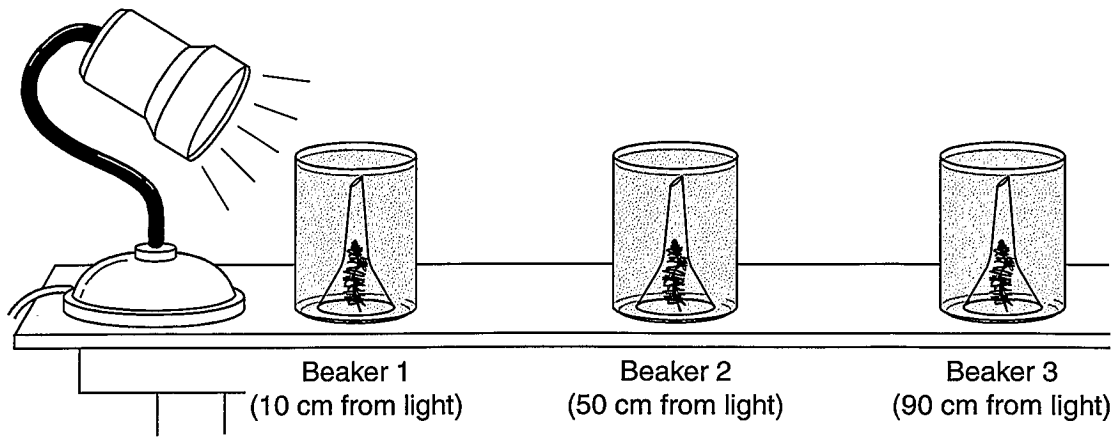

3 The picture shows an experiment designed to investigate biochemical activity in a water plant in a dark room. Over time, bubbles can be easily observed and counted as they escape from the funnel. The number of bubbles is an indicator of the rate of photosynthesis. Which of these data tables best reflects the expected results of this experiment?

A

Beaker	Number of Bubbles/Minute
1	0
2	15
3	20

C

Beaker	Number of Bubbles/Minute
1	15
2	15
3	15

B

Beaker	Number of Bubbles/Minute
1	10
2	0
3	20

D

Beaker	Number of Bubbles/Minute
1	20
2	10
3	0

Characteristics of Some Lizards

- Live mainly in hot, dry climates
- Release very little water
- Excrete waste in the form of solid uric acid, which contains very little water

- 4 Which of the following is best supported by the information shown above?
- F** These lizards evolved in arid habitats.
- G** Modern lizards drink more water than their ancestors did.
- H** These lizards cool themselves by evaporation.
- J** Modern lizards excrete more water than their ancestors did.

A De-Icing Experiment

Some species of plants that commonly grow near roadways are used in an experiment. The plant species are divided into control groups and experimental groups. All groups are grown under identical conditions except that the experimental groups are given daily applications of a de-icing solution that is used on roadways in winter. At the end of one month, the growth of the control and experimental groups is compared.

- 5 Which of the following is the most likely hypothesis for the experiment described above?
- A** Vegetation that grows near roadways requires more water than vegetation in other areas.
- B** De-icing solution causes roadways to have more space for vegetation.
- C** Vegetation near roadways changes the effectiveness of de-icing solution.
- D** De-icing solution affects some types of vegetation that grow near roadways.

Hand-Washing Habits and Absenteeism Among Elementary School Students

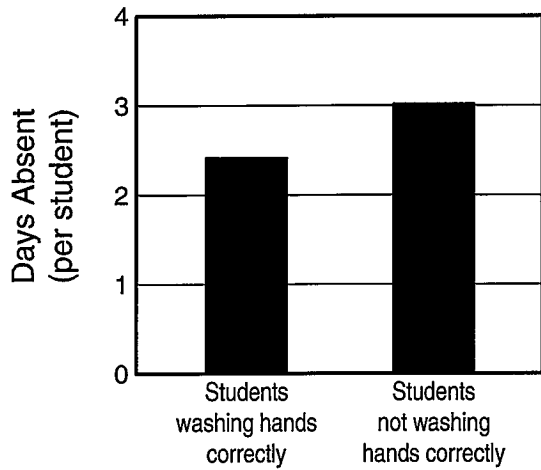

- 6 The graph compares absenteeism of elementary school students who wash their hands properly with absenteeism of students who fail to wash their hands properly. Which inference could best be supported by these data?
- F Proper hand washing may increase attendance among elementary school students.
 - G Older students have developed better hand-washing habits than younger students.
 - H Some elementary school classes teach correct hand-washing methods to students.
 - J Improper hand washing is a common practice among most elementary school students.

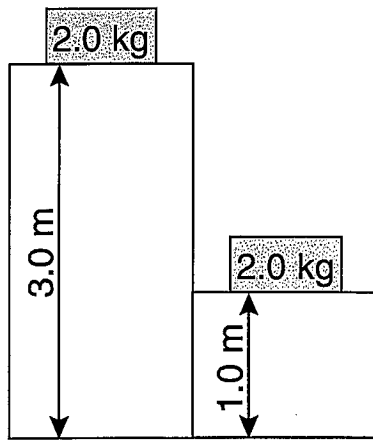

- 7 What is the approximate difference in gravitational potential energy of the two shaded boxes?
- A 19 J
 - B 39 J
 - C 59 J
 - D 79 J

- 8 A hockey player pushed a puck toward the opposite side of a level ice rink. The player expected the puck to continue all the way across the ice, but the puck slowed and stopped before reaching the other side. Which of these best explains why the puck failed to slide all the way to the opposite side?
- F The puck's temperature changed.
 - G An upward force acted on the puck.
 - H The puck's momentum remained unchanged.
 - J An opposing force acted on the puck.

- 9 Which of these is an advantage of producing electricity using solar power plants rather than using coal-fired power plants?
- A Solar power plants can operate for about 10 hours per day.
 - B Solar power plants can produce variable amounts of energy.
 - C Solar power plants produce fewer pollutants.
 - D Solar power plants require continuous sunlight.

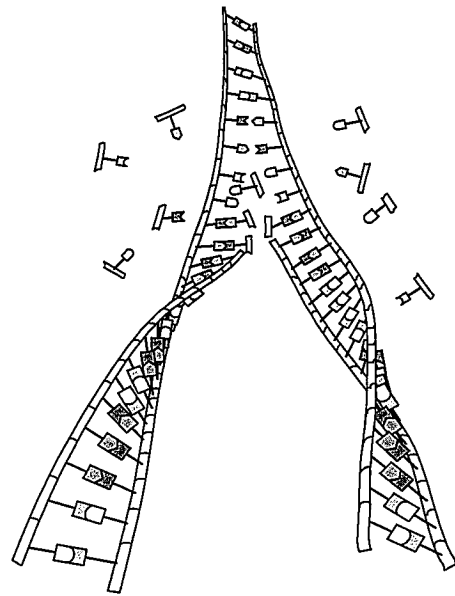

- 10 If one nucleotide is omitted or accidentally repeated in the process of DNA duplication, which of the following is most likely to occur?
- F Gene deletion
 - G Gene mutation
 - H Gene insertion
 - J Gene segregation

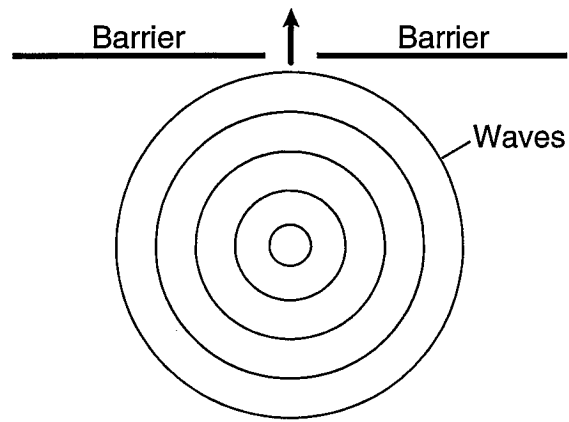

- 11 The diagram shows waves approaching a barrier. Which pattern will be formed after the waves pass through the opening in the barrier?

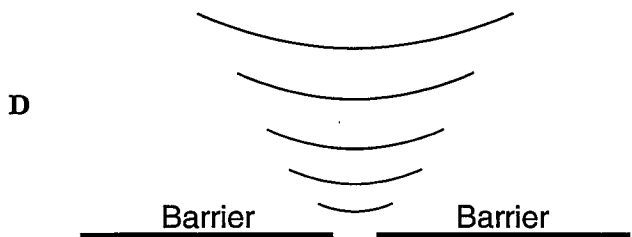
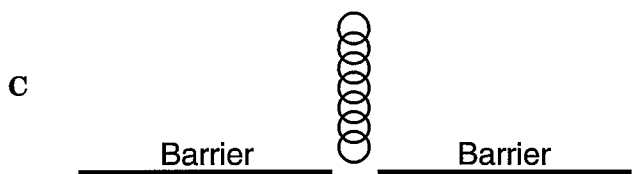
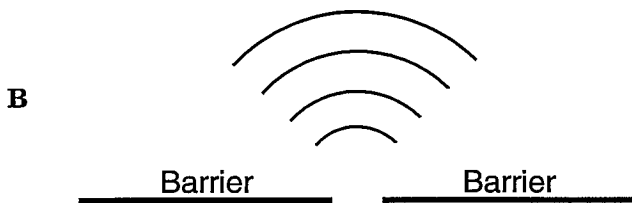
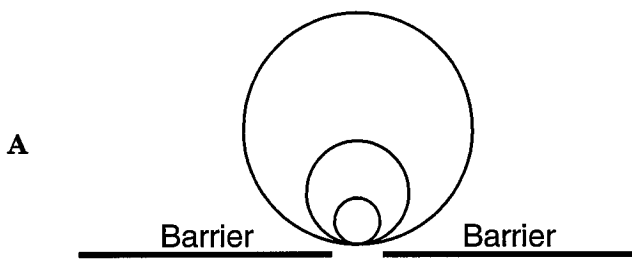

Use the information below and your knowledge of science to answer questions 14–17.

Black-and-White Negatives

Before digital cameras were available, photographs could be made only with cameras that used photographic film. These cameras are still in use today.

Photographic film contains a light-sensitive layer of chemicals. These chemicals are silver halide granules. As light rays travel through a camera lens, they bend and are focused onto the photographic film. When exposed to light, the silver halide granules are activated in different amounts depending on the intensity of the light that strikes them. This forms a photographic image on the film.

After the pictures are taken, the exposed film is processed in a laboratory. The film is placed in a solution that reacts chemically with the silver halide granules, forming black metallic silver. The black silver is thickest in the areas of the film exposed to the most intense light and thinnest in the areas exposed to the least intense light.

After a roll of film is processed, it is called a negative. This is because it contains negative images of the pictures that were taken. When light is projected through the negatives onto photosensitive paper, the areas with the thickest silver become the lightest, and the areas with the thinnest silver become the darkest.

The diagram shows both a negative image and a positive image of a tree. The negative image represents an image on the negative, and the positive image represents the same image on photo paper.

Negative Image Positive Image



- 14 In photography, which of these is an example of a chemical change?
- F Light being refracted by a camera lens
 - G Adjusting a lens to focus light
 - H Halide granules being activated by light
 - J Allowing a certain wavelength of light into the camera

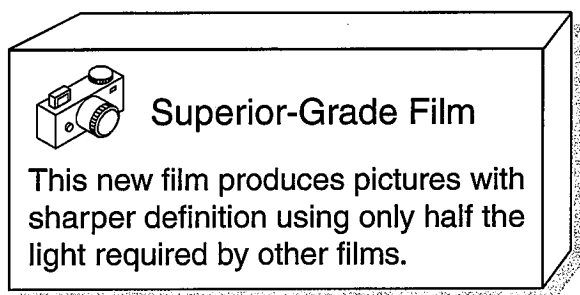

- 15 Which of the following would explain why this film works with a reduced amount of light?
- A The film reflects long wavelengths of light efficiently.
 - B Fewer silver halide granules are present in the film.
 - C The film refracts brighter light.
 - D The photochemical reaction can occur in lower intensity light.

- 16 Which of these tools is most useful in identifying the wavelengths of visible light?
- F Convex lens
 - G Spectroscope
 - H Microscope
 - J Concave mirror

- 17 Silver bromide is a type of halide. Elements from which group in the periodic table are necessary to form halide compounds?
- A Group 4
 - B Group 5
 - C Group 10
 - D Group 17

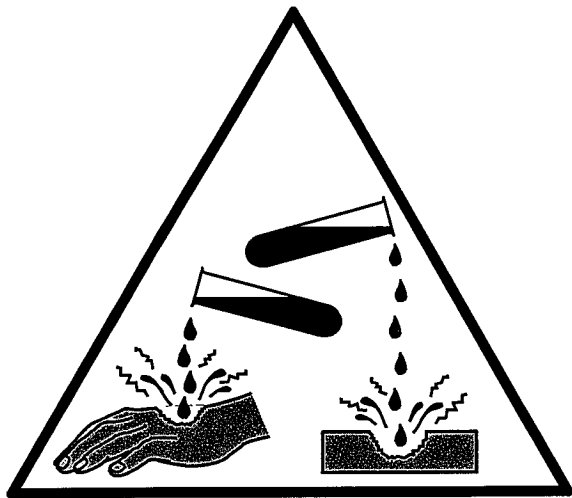

18 This picture indicates that the chemical represented is —

- F pressurized
- G corrosive
- H flammable
- J toxic

19 Which of these devices uses the sun's energy directly?

- A Windmill
- B Hydroelectric dam
- C Nuclear power plant
- D Photovoltaic cell

Car velocity = 6.3 m/s
Driver velocity = 6.3 m/s
Driver mass = 100 kg

Car velocity = 0 m/s
Driver velocity = 6.3 m/s
Driver mass = 100 kg

Car velocity = 0 m/s
Driver velocity = 0 m/s
Driver mass = 100 kg

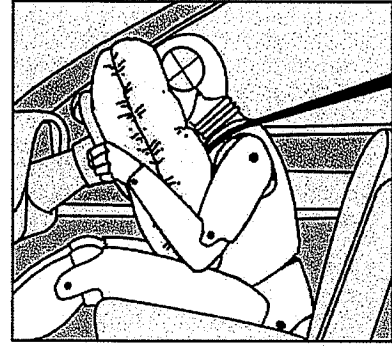
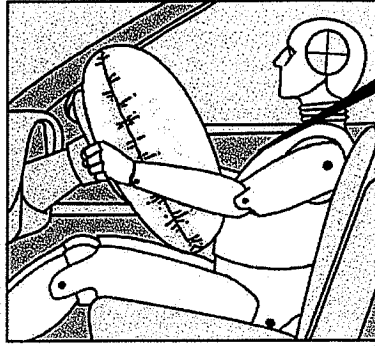
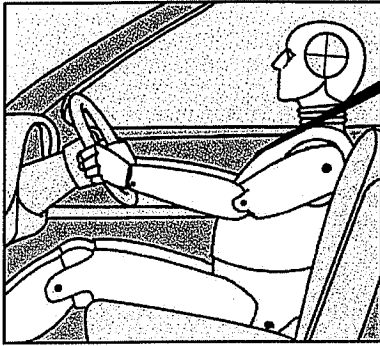

- 20 The pictures show how an air bag functions in a collision. How much momentum in kg m/s does the air bag absorb from the crash-test dummy if all the crash-test dummy's momentum is absorbed by the air bag? Record and bubble in your answer to the nearest whole number on the answer document.

Experimental Preparation

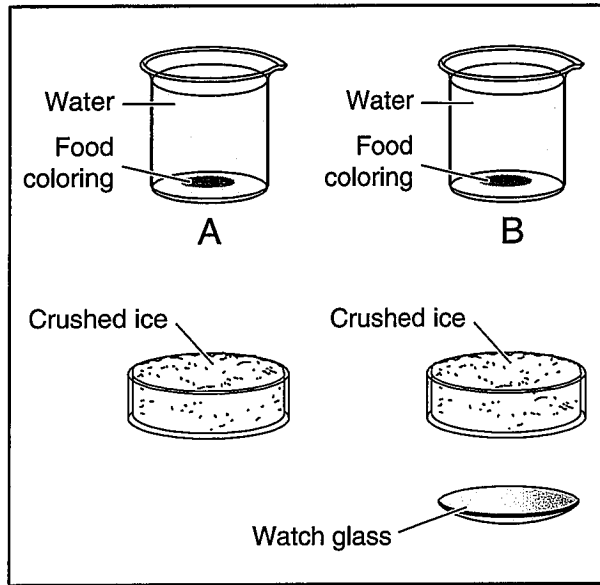

Experiment

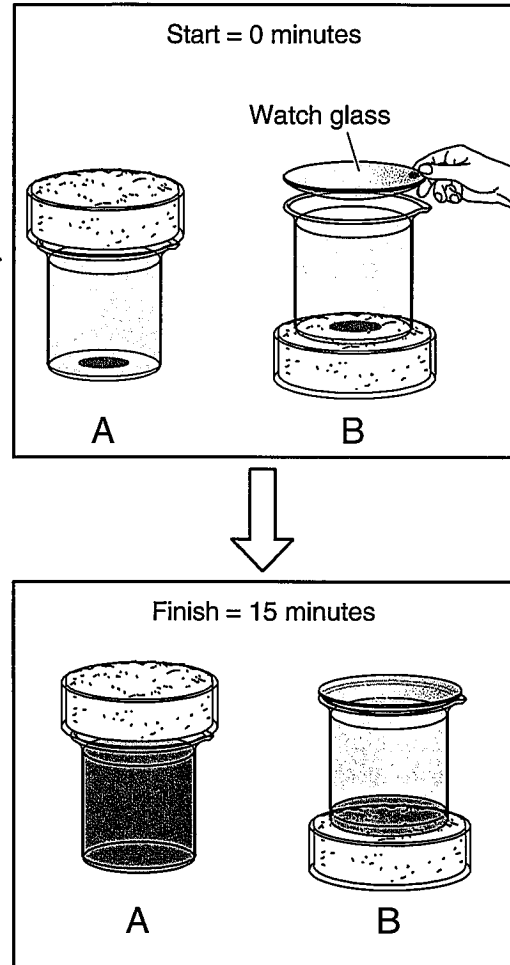

21 After 15 minutes the food coloring in Beaker A is evenly spread throughout the beaker, while Beaker B contains a thin layer of food coloring only at its bottom. These observations support the theory that convection currents in a fluid form more quickly if the fluid has —

- A warmer layers at the bottom
- B a covering on its surface
- C reduced pressure on the bottom
- D contact with a cooler surface

Research shows that levels of a certain protein are elevated in the blood of people with a bacterial infection. People with a viral infection show only trace amounts of the protein. The level of the protein can be determined in about an hour after a blood test.

- 22 Which of these is a benefit of knowing whether a person with a respiratory infection has an elevated level of this protein in the blood?
- F A set of aerobic exercises can be recommended.
 - G A diet of essential nutrients can be recommended.
 - H A decision can be made about whether to take an x-ray.
 - J A decision can be made about whether to use antibiotics.

- 23 Which of these is a characteristic of body cells that require large amounts of energy?
- A They have a large number of mitochondria.
 - B They have a supplementary Y chromosome.
 - C They have a two-layer membrane.
 - D They have a storage area for albumin proteins.

- 24 A 1-kilogram ball has a kinetic energy of 50 joules. The velocity of the ball is —
- F 5 m/s
 - G 10 m/s
 - H 25 m/s
 - J 50 m/s

Food is digested in the gastrointestinal tract to provide nutrients to the body. In addition, various hormones secreted from the lining of a few digestive organs allow other organs to function properly.

- 25 According to this information, some organs of the gastrointestinal tract —
- A fit in more than one organ system
 - B perform only one function at a time
 - C supply the body with platelets
 - D produce soluble vitamins

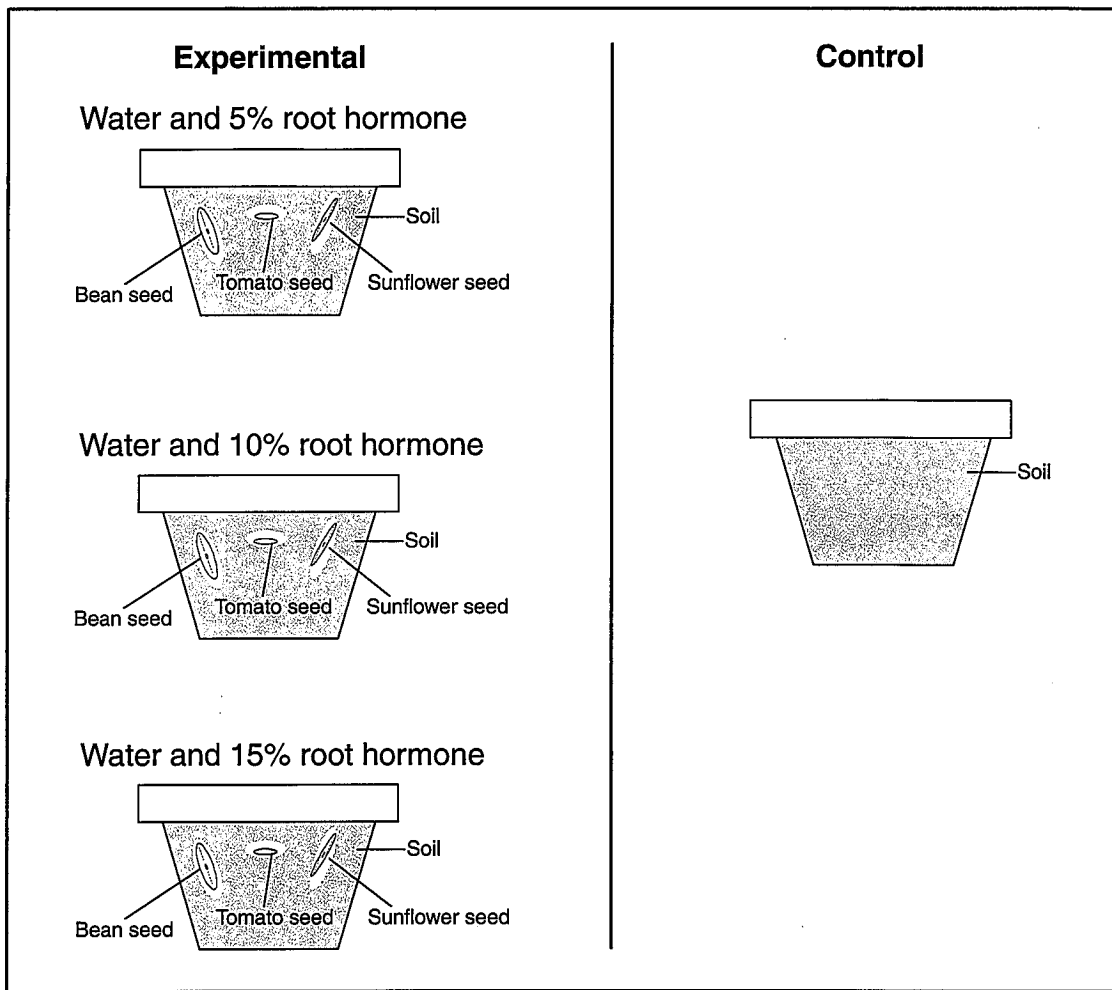

26 A valid study would include a control group containing —

- F bean seed, tomato seed, sunflower seed, and water
- G water and 2% root hormone
- H water only
- J bean seed, tomato seed, sunflower seed, water, and 1% root hormone

- 27 Which of these would support the idea that mass is conserved in a reaction that produces a gas as a product?
- A Heating the reactants to ensure the reaction occurs in a gaseous state
 - B Subtracting the mass of the gas from the mass of the solid and liquid products
 - C Mixing the reactants and measuring their total mass
 - D Trapping the gas and measuring its mass

- 28 A company has decided to market itself as environmentally friendly. If the company is going to sell calculators, the use of which energy source would produce the fewest by-products and the least waste?
- F Rechargeable batteries
 - G Solar cells
 - H Dry-cell batteries
 - J Tesla coils

Properties of Some Solutions

Solution	Electrical Conductivity of Solution	Original Color of Litmus Paper	Color of Litmus Paper After Dipping in Solution	pH
1	Very high	Red	Blue	10.0
2	Low	Blue	Red	6.5
3	Moderate	Red	Red	5.4
4	Very high	Blue	Red	2.0

29 The table shows data from an investigation designed to find a liquid solution that is both an acid and a strong electrolyte. Based on the data, a solution that is both an acid and a strong electrolyte is —

- A Solution 1
- B Solution 2
- C Solution 3
- D Solution 4

30 A researcher determined the percentage of electrical energy transformed into different forms of energy by a toaster. The best way to communicate these results is to display the data using a —

- F histogram
- G circle graph
- H line graph
- J box-whisker graph

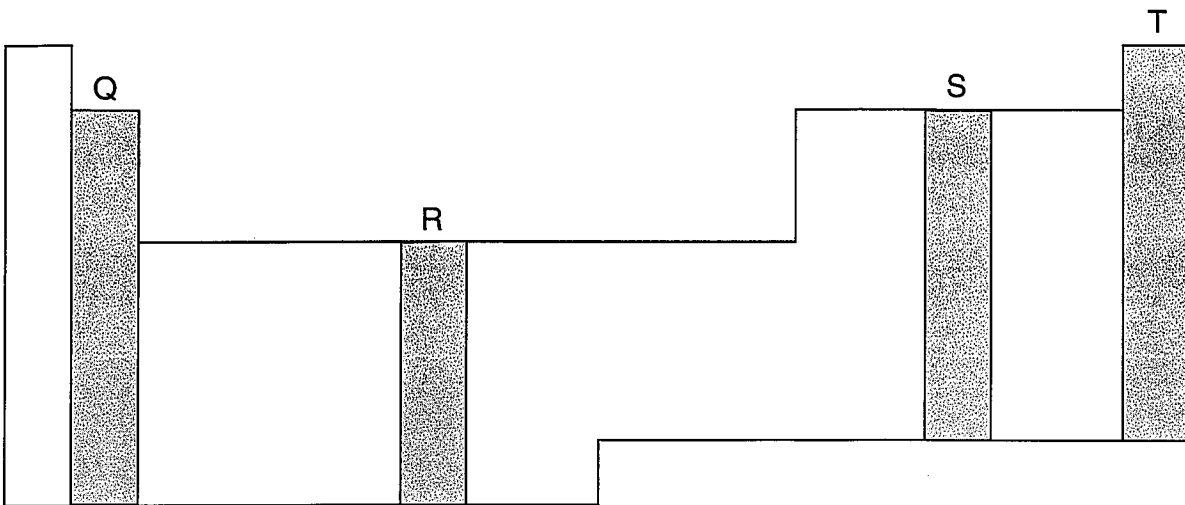

31 Elements found in which shaded area of this periodic table undergo the fewest chemical reactions?

- A Q
- B R
- C S
- D T

32 A deletion of a DNA base from a gene affects an organism by —

- F causing future gametes to have additional chromosomes
- G changing the sequence of amino acids in a protein
- H causing chromosome fragments to form long chains
- J changing the structure of ribose sugar in nucleic acids

Empty glass

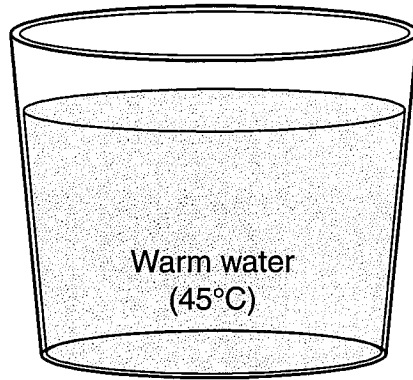
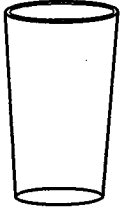

Before

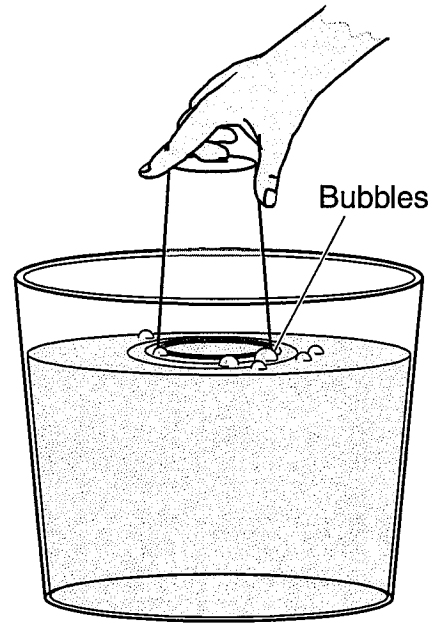

After

- 33 A glass is held upside down so that its open end is closed by the water's surface. Soon air bubbles begin to escape from the glass. The best explanation for this observation is that —
- A water condenses on the glass and escapes as a gas
 - B air in the glass increases the water temperature and causes bubbling
 - C pressurized water vapor rises rapidly and evaporates
 - D air trapped in the glass is warmed and expands in volume

34 According to the periodic table, which of these elements will form an ion with a -2 charge?

- F S
- G Mg
- H F
- J Rb

35 Because chewing begins the breakdown of food before it is swallowed, digestion starts in the mouth and throat. Which of the following systems aids most in this early stage of digestion?

- A Immune system
- B Excretory system
- C Muscular system
- D Respiratory system

36 *Streptococcus* infection in a person's throat can cause pain and fever. *Streptococcus* can be controlled by antibiotics. *Streptococcus* is a —

- F virus
- G bacterium
- H protozoan
- J fungus

- Cytochrome c is a protein found in all aerobic organisms.
- The differences in the amino acid sequence of cytochrome c are used to determine how closely species are related.

Percent Differences in Cytochrome c

	Horse	Dog	Kangaroo	Penguin
Horse	0	6	7	12
Dog	6	0	7	10
Kangaroo	7	7	0	10
Penguin	12	10	10	0

- 37 The table above shows percent differences in cytochrome c in four different animals. According to the table, which two animals are most closely related to each other?
- A Horse and dog
 - B Dog and kangaroo
 - C Horse and penguin
 - D Penguin and kangaroo

- 38 As the viscosity of a liquid increases, the liquid —
- F conducts electricity
 - G pours more slowly
 - H evaporates more quickly
 - J forms a precipitate

- 39 A guitar player is seated next to a piano. The piano player strikes an E key on the piano. The guitarist reports that this causes the E string on his guitar to vibrate. What is the name of this phenomenon?
- A Polarization
 - B Resonance
 - C Reflection
 - D Diffraction

40 Which of these is the most appropriate unit of measure for reporting the density of a solid?

- F g/cm^3
- G g/cm
- H g/L^2
- J g/mm^2

41 Which of the following must occur before DNA replication can take place?

- A Translation of DNA into amino acids
- B Separation of the DNA molecule into codons
- C Transformation of DNA into RNA
- D Separation of the DNA double helix

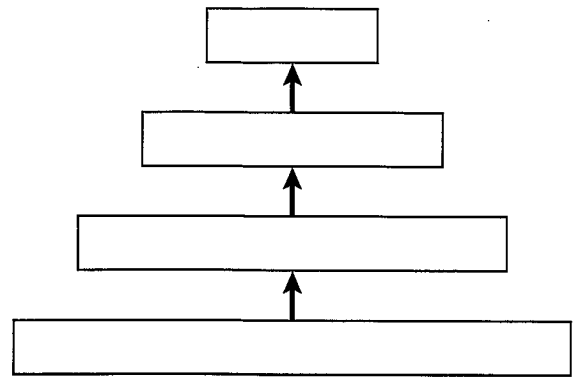

42 The diagram above is intended to show relationships in an ecosystem. What do the arrows represent?

- F The direction of population migration
- G Differences in dietary habits
- H Progressively smaller organisms
- J The direction of energy flow

43 Water normally boils at 100°C at sea level and at 97°C on a North American mountaintop. This difference in boiling points can be explained by the difference between the locations' —

- A ultraviolet light
- B air pressure
- C gravitational force
- D thermal energy

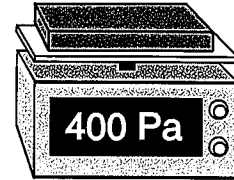
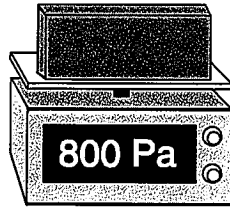
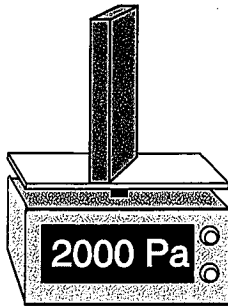

44 The pictures show a 10-newton block of wood being used to demonstrate how this instrument measures pressure. According to these data, the pressure of the block is a measure of the block's —

- F weight distributed over an area
- G density along each face
- H mass per unit of volume
- J change in inertia

- 45 Saltwater fish remove extra salt from their body by active transport through the gills. What is the result of this activity?
- A The salt becomes more chemically active.
 - B Water balance is maintained in the blood.
 - C The rate of energy production is decreased.
 - D The cell membrane becomes less permeable to water.

- 46 Insecticides help humans compete with insects for a resource. Which resource is most likely to be preserved for humans through the use of insecticides?
- F Sunlight
 - G Water
 - H Food
 - J Air

Information About Sendai Virus

- Some infants and children are infected with human parainfluenza virus type 1, also known as HPIV-1.
- A vaccine against HPIV-1 is made of a low dose of Sendai virus.
- Sendai virus has a similar structure to HPIV-1.
- Sendai virus makes mice sick but does not make humans sick.

47 Why is Sendai virus used as a vaccine against HPIV-1?

- A It alters the protein coat of HPIV-1.
- B It makes cells chemically unrecognizable to HPIV-1.
- C It forms a protective barrier against HPIV-1.
- D It triggers the production of antibodies that fight HPIV-1.

48 The buoyant force that a fluid exerts on objects is increased when there is an increase in the fluid's —

- F acidity
- G clarity
- H solubility
- J density

49 A student is working with four beakers that each contain a clear liquid. Which set of procedures would be best to use to determine whether one of the beakers contains only distilled water?

A

Observe odor
Determine temperature
Observe color
Determine boiling point

B

Observe odor
Determine pH
Determine density
Determine boiling point

C

Observe volume
Determine mass
Observe color
Determine pH

D

Determine mass
Observe volume
Determine temperature
Observe odor

Examples of Group 2 elements		Examples of Group 16 elements		
2Mg	+	O ₂	→	2MgO
Ca	+	S	→	CaS

50 The ionic compounds that result from combining Group 2 and Group 16 elements have a 1:1 ratio because —

- F Group 2 elements are electrically neutral
- G Group 2 elements have two valence electrons
- H Group 2 elements contain neutrons in the nucleus
- J Group 2 contains more elements than other groups

51 Some species of kelp anchor themselves to the seafloor. These species have small air sacs, called air bladders, at the base of each leaf. The air bladders raise the top of the kelp to the water's surface. What advantage do air bladders give the kelp?

- A They allow the kelp to obtain more salt from the water.
- B They prevent the kelp from breaking during a storm.
- C They allow kelp leaves to receive greater amounts of sunlight.
- D They provide the kelp with protection from herbivores.

52 Which of the following is a change that could be passed on to an organism's offspring?

- F Damage to the DNA of gamete cells
- G Damage to skin cells from exposure to sunlight
- H Damage to DNA in the cytoplasm of cheek cells
- J Damage to hair pigment cells with permanent dyes

53 A 0.50 kg ball with a speed of 4.0 m/s strikes a stationary 1.0 kg target. If momentum is conserved, what is the total momentum of the ball and target after the collision?

- A 0.0 kgm/s
- B 0.5 kgm/s
- C 1.0 kgm/s
- D 2.0 kgm/s

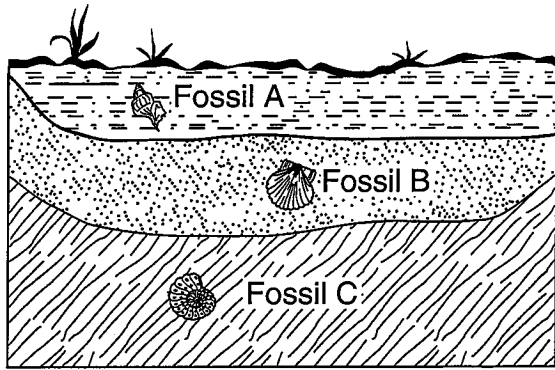

- 54 Which conclusion is best supported by the information in the diagram?
- F Volcanic eruptions were common in the area.
 - G The area was once a marine environment.
 - H Organisms in the area reproduced frequently.
 - J Consumers once outnumbered producers in the area.

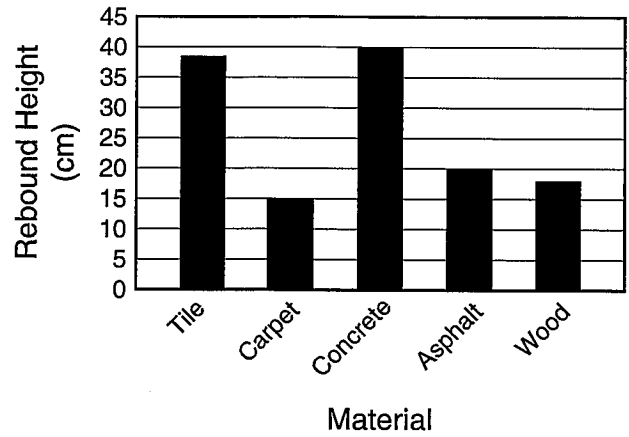

- 55 In an activity, a ball is dropped from a height of 100 cm onto five different materials. The rebound height of each drop is shown in the graph. Which of the following describes the hypothesis most likely being tested?
- A The mass of the ball affects the rebound height.
 - B The material the ball is made of affects the rebound height.
 - C The height the ball is dropped from affects the rebound height.
 - D The surface the ball is dropped onto affects the rebound height.

BE SURE YOU HAVE RECORDED ALL OF YOUR ANSWERS
ON THE ANSWER DOCUMENT.



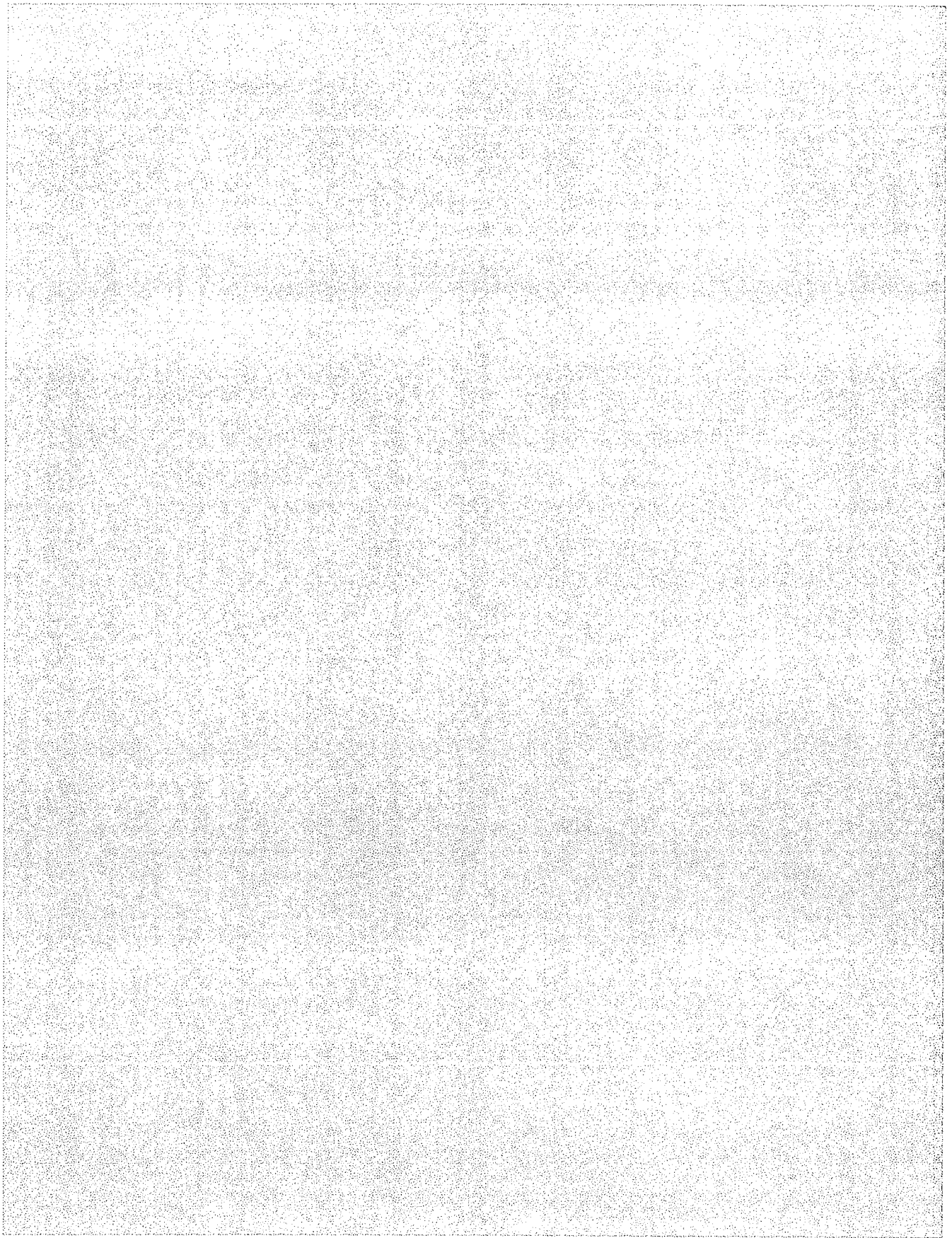

SOCIAL STUDIES

DIRECTIONS

Read each question and choose the best answer. Then fill in the correct answer on your answer document.

SAMPLE A

Who served as president of the United States during the Civil War?

- A Thomas Jefferson
- B Andrew Jackson
- C James K. Polk
- D Abraham Lincoln



Use the cartoon and your knowledge of social studies to answer the following question.

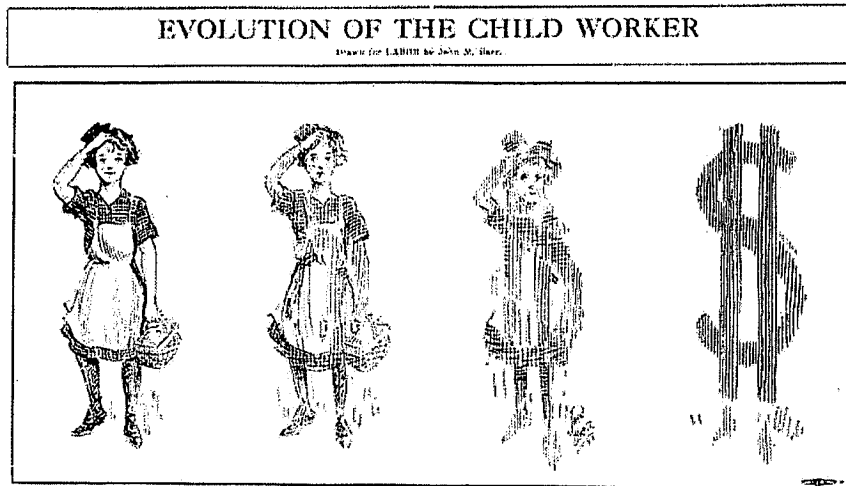

- 1 The cartoon above illustrates the artist's negative opinion concerning the exploitation of children in industry by showing a child —
- A carrying an empty basket, which signifies hunger and a lack of sufficient food
 - B giving a salute, which signifies respect
 - C turning into a dollar sign, which signifies that profits are valued above people
 - D dressing like a maid, which signifies low social status

Use the photograph and your knowledge of social studies to answer the following question.



Source: CORBIS

- 2 The type of housing shown above was necessary because many Native Americans living on the Great Plains —
- F needed easy access to railroad lines
 - G wanted to hide their identity from the U.S. Army
 - H were always on the move in search of buffalo
 - J needed permanent residences in order to practice agriculture

Use the information in the box and your knowledge of social studies to answer the following question.

- Unhealthy working conditions
- Unequal distribution of wealth
- Long working hours for little pay
- Growing incidence of wage cuts

3 The conditions listed above best explain the growth of —

- A farmer alliances
- B urban areas
- C national railroads
- D labor unions

Use the map and your knowledge of social studies to answer the following question.

Spanish Viceroyalties in the Western Hemisphere

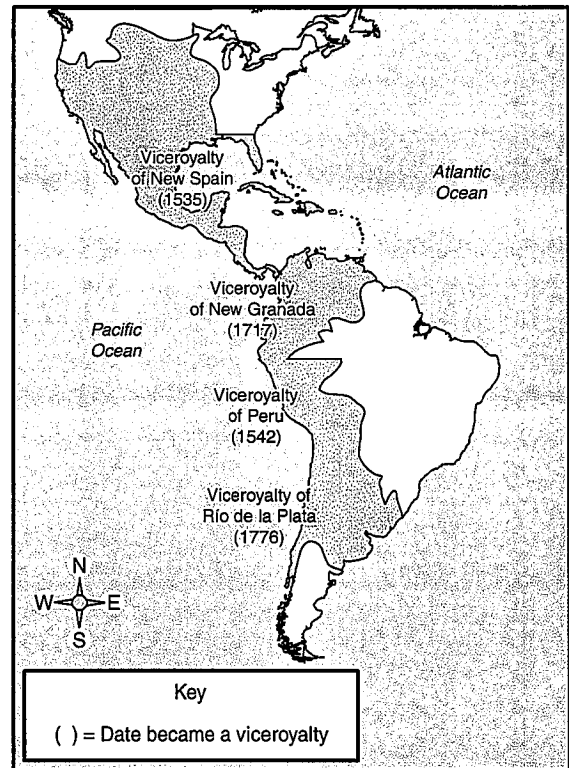

4 Which of the following statements about viceroyalties does the map best support?

- F They extended across two continents.
- G They furnished riches to France.
- H They originated in the same century.
- J They dominated trade with Europe.

Use the diagram and your knowledge of social studies to answer the following question.

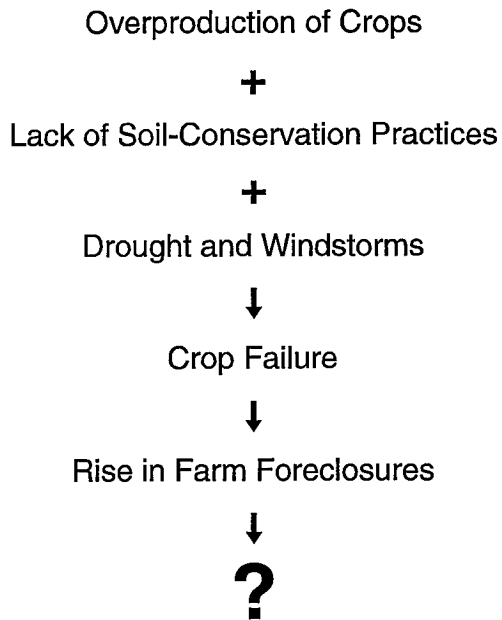

- 5 Which of the following best completes the diagram above?
- A Growth of the Banking Industry
 - B Suspension of Government Assistance
 - C Increase in Farm Production on the Great Plains
 - D Mass Migration of Farmers from the Dust Bowl

Use the illustration and your knowledge of social studies to answer the following question.

Unalienable Rights

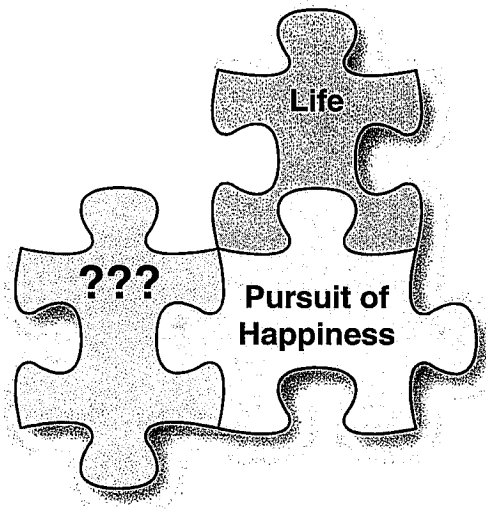

- 6 Which of the following best completes the diagram?
- F Liberty
 - G Justice
 - H Equality
 - J Property

Use the information in the box and your knowledge of social studies to answer the following question.

- Lunch-counter sit-ins
- Montgomery bus boycott
- March on Washington
- Freedom Summer

- 7 The events listed above occurred as part of the —
- A women's rights movement
 - B Progressive movement
 - C antiwar movement
 - D Civil Rights movement

Use the excerpt and your knowledge of social studies to answer the following question.

Excerpt from the Declaration of Independence

That to secure these rights, governments are instituted among men. . . . [W]henver any form of government becomes destructive of these ends, it is the right of the people to alter or to abolish it. . . .

- 8 It can best be supported from the excerpt above that if a person's unalienable rights are not protected by the government, then the people have —
- F the right to change the government
 - G the opportunity to adjust government spending
 - H the obligation to obey unfair laws
 - J the responsibility to finance political campaigns
- 9 The primary purpose for the creation of the Federal Deposit Insurance Corporation (FDIC) was to —
- A oversee a system of pensions for the elderly
 - B stabilize financial institutions of the United States
 - C establish relief agencies for the needy
 - D pay subsidies to American farmers

Use the image and your knowledge of social studies to answer the following question.



Source: NARA

- 10 How did the person depicted in the image above most influence American culture immediately after his historic flight in 1927?
- F He helped negotiate the Treaty of Versailles and end German militarism.
 - G He promoted military spending during World War II.
 - H He was treated as a hero and inspired a sense of hope.
 - J He helped end nativism by spreading European traditions.

Use the information in the box and your knowledge of social studies to answer the following question.

Bureau of Reclamation

- Established in 1902
- Constructed dams, power plants, and canals in 17 western states
- Sells water wholesale
- Provides irrigation to the farmland that produces 60 percent of the vegetables in the United States
- 58 power plants provide electricity to six million homes

Source: U.S. Department of Interior,
Bureau of Reclamation

- 11 According to the information in the box, the Bureau of Reclamation actively promotes the —
- A exploration for oil in the region
 - B election of conservation-friendly political candidates
 - C growth of farmworkers' unions
 - D economic development of the region

Use the diagram and your knowledge of social studies to answer the following question.

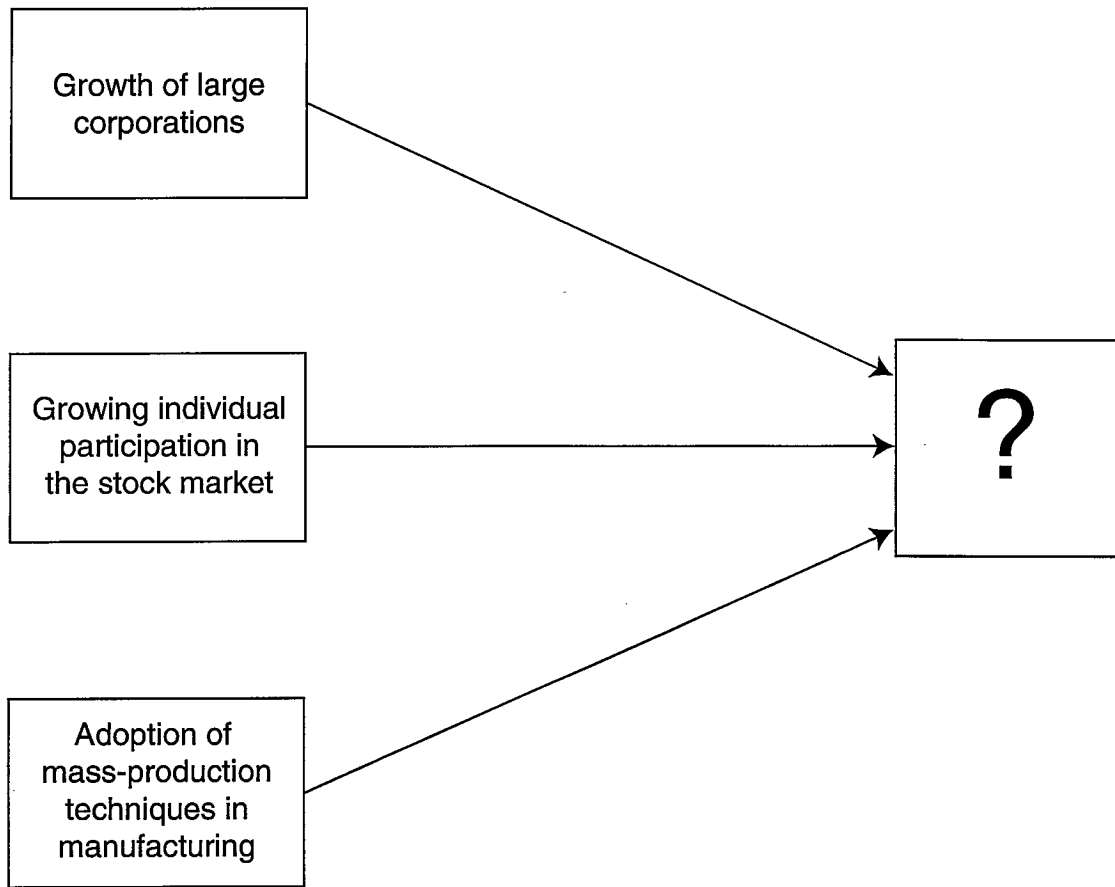

12 Which of the following best completes the diagram above?

- F Causes of U.S. participation in World War I
- G Results of the completion of the Panama Canal
- H Causes of the economic boom of the 1920s
- J Effects of early-20th-century political reforms

Use the map and your knowledge of social studies to answer the following question.

World War I in Europe

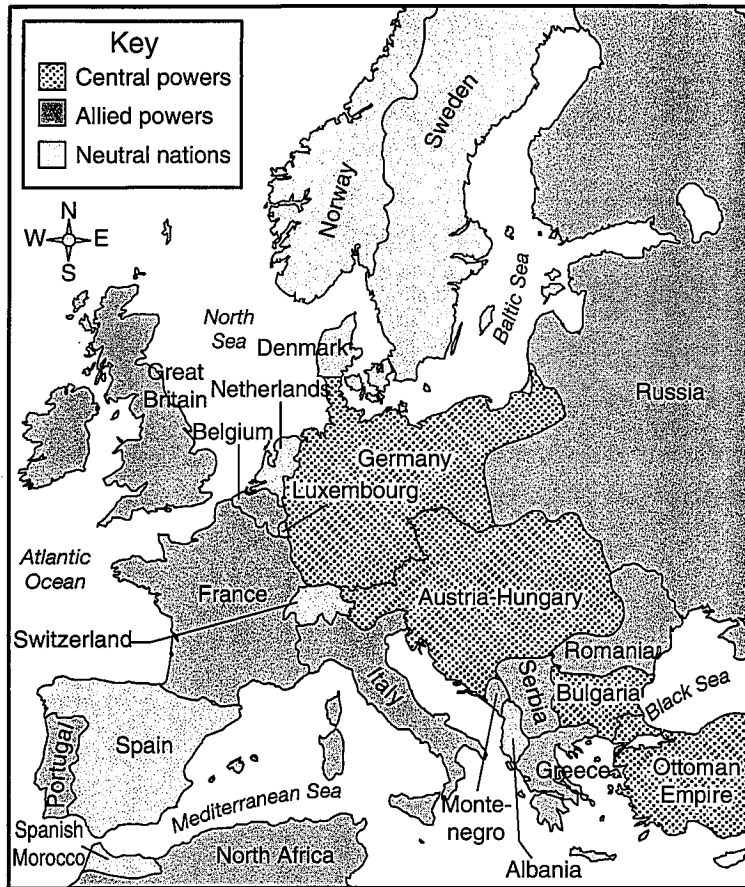

13 According to the map, which nations were allies during World War I?

- A France and Spain
- B Germany and Bulgaria
- C Greece and Sweden
- D Norway and Portugal

Use the excerpt and your knowledge of social studies to answer the following question.

Ten years ago the place where we gathered was an unpeopled, forbidding desert. . . . We are here to celebrate the completion of the greatest dam in the world. . . . Beautiful and great as this structure is, it must also be considered in its relationship to the agricultural and industrial development and in its contribution to the health and comfort of the people . . . who live in the southwest.

— *Excerpt from Franklin D. Roosevelt's
Dedication Day speech, 1935*

14 In the dedication of the Hoover Dam described above, President Roosevelt suggested that —

- F water would now be available for irrigation
- G missing soil nutrients would be replaced
- H trees lost in the clearing of farmland would be replanted
- J contour plowing would prevent soil erosion

15 Which of the following took place from 1914 to 1918?

- A The Great Depression
- B World War I
- C The Populist movement
- D The Spanish-American War

Use the excerpt and your knowledge of social studies to answer the following question.

It ought to be possible for American consumers of any color to receive equal service in places of public accommodation, such as hotels and restaurants and theaters and retail stores, without being forced to resort to demonstrations in the street. . . .

— *President John F. Kennedy,*
Address to the Nation

16 Which of the following legislative acts addressed the issue referred to in this statement by President Kennedy?

- F Economic Opportunity Act of 1964
- G Equal Access Act
- H Equal Pay Act
- J Civil Rights Act of 1964

17 In the early 1900s President Theodore Roosevelt used the Big Stick policy to involve the United States in the building of the Panama Canal. Which of the following benefits was accomplished with this construction?

- A Political alliances with European governments were created.
- B Colonies in West Africa were acquired.
- C Shipping time for world trade was decreased.
- D European colonies in Latin America were granted immediate independence.

18 Which of the following was an underlying cause of the Great Depression?

- F Increased government regulation of the stock market
- G Low tariffs to increase international trade
- H Overproduction of consumer goods
- J Economically strong farm sector

Use the time line and your knowledge of social studies to answer the following question.

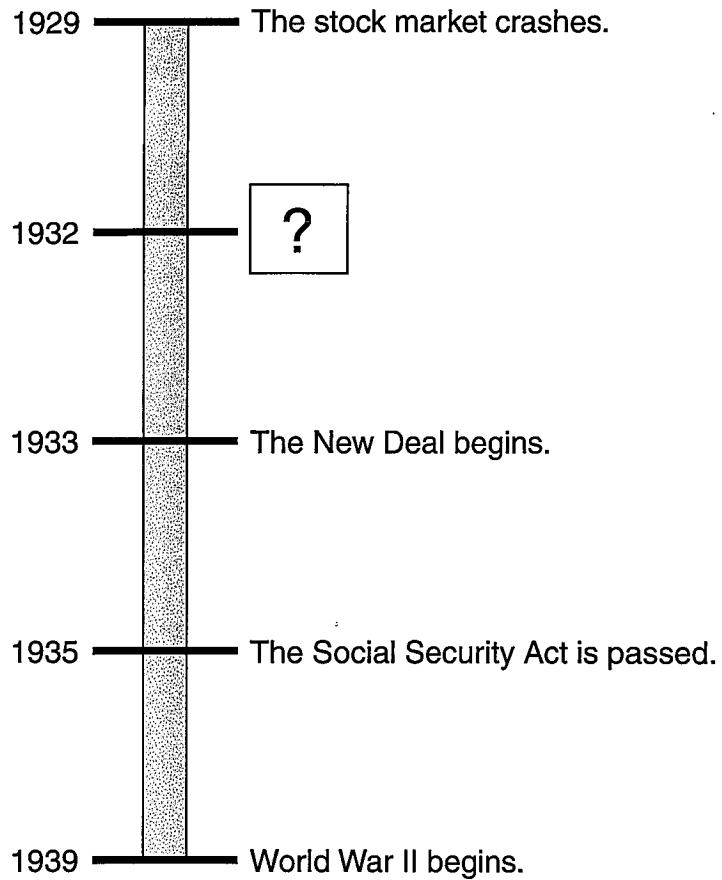

19 Which of the following best completes the time line?

- A Franklin D. Roosevelt is elected president.
- B The Teapot Dome scandal is exposed.
- C Women gain the right to vote.
- D The League of Nations is formed.

20 What was the significance of the Battle of Midway?

- F** It led to U.S. entry into World War II.
- G** It forced Japan to surrender.
- H** It ended Japan's naval superiority in the Pacific.
- J** It led to the formation of the United Nations.

Use the graph and your knowledge of social studies to answer the following question.

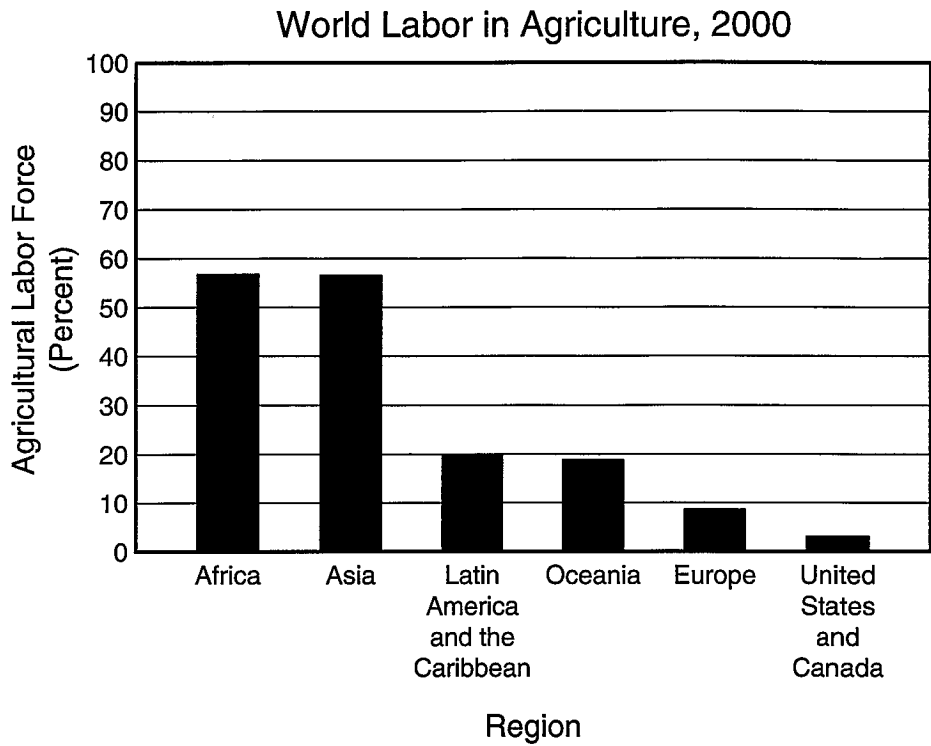

Source: United Nations Food and Agriculture Organization

- 21 The graph above can be used to answer which of the following questions about the year 2000?
- A How many workers in the world are members of the agricultural labor force?
 - B How does the percent of agricultural laborers differ between Africa and Europe?
 - C How long has Asia had a majority of its labor force involved in agriculture?
 - D How many foreign workers are involved in agriculture in the United States and Canada?

Use the information in the box and your knowledge of social studies to answer the following question.

Principles of the Magna Carta

- A rule of law should limit the power of the king.
- Certain basic rights should be protected.
- Government should be based on an agreement between the ruler and the ruled.

22 According to the information above, the Magna Carta most influenced the colonial development of —

- F judicial review
- G federalism
- H representative government
- J feudalism

Use the diagram and your knowledge of social studies to answer the following question.

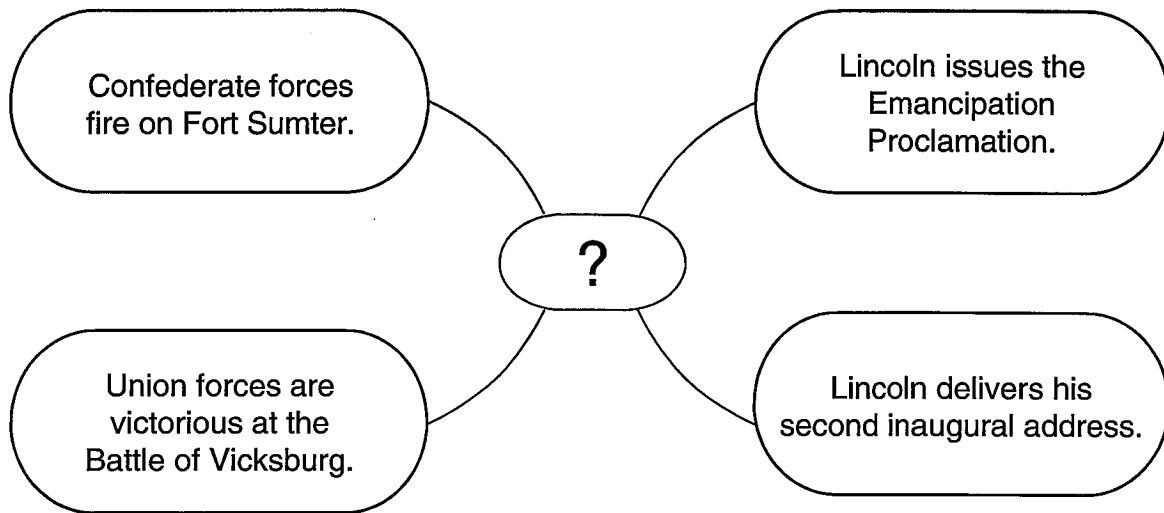

23 Which of the following date ranges best completes the diagram?

- A 1776–1781
- B 1846–1848
- C 1812–1814
- D 1861–1865

24 Which of the following documents lists the reasons for the Revolutionary War?

- F U.S. Constitution
- G Declaration of Independence
- H Articles of Confederation
- J Bill of Rights

Use the information in the box and your knowledge of social studies to answer the following question.

- Created in 1949 as a mutual-defense alliance
- Initially included 12 democratic nations
- Prompted by the Berlin blockade
- First commitment to a mutual-defense alliance by the United States

25 The information listed above describes which of the following agreements?

- A Warsaw Pact
- B Strategic Arms Limitation Talks
- C Atlantic Charter
- D North Atlantic Treaty Organization

Use the cartoon and your knowledge of social studies to answer the following question.

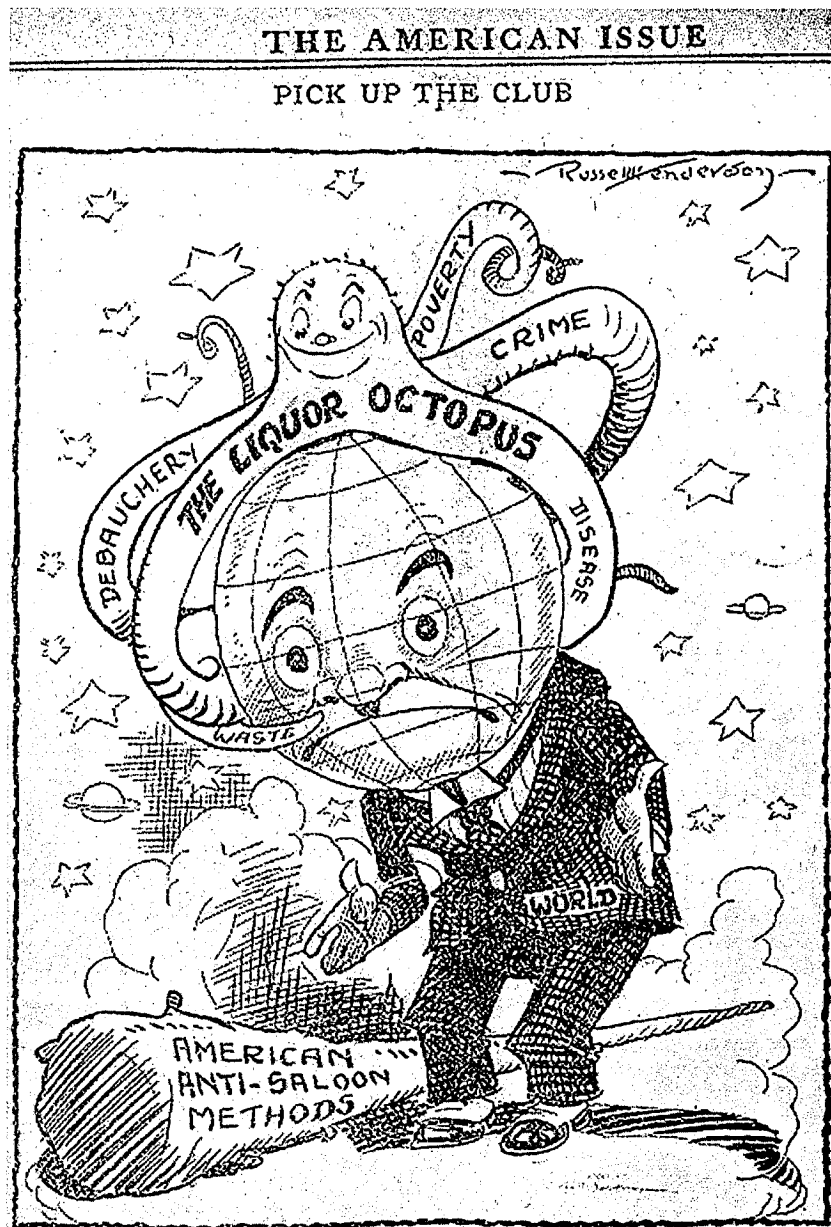

Source: Westerville Public Library

- 26 The point of view expressed in the cartoon is that —
- F the methods used by the Anti-Saloon League contributed to liquor consumption
 - G aggressive measures were necessary to address the evils of liquor
 - H poverty and crime were not the direct result of liquor consumption
 - J disease and waste were caused by the actions of the Anti-Saloon League

27 Which of the following most influenced President Woodrow Wilson's decision to ask for a declaration of war against Germany?

- A** The assassination of Archduke Franz Ferdinand
- B** Germany's treatment of prisoners of war
- C** The German use of aerial bombing raids
- D** The Zimmermann telegram

28 Ratification of the 17th Amendment gave the people a greater voice in government by providing for —

- F** direct election of U.S. senators
- G** federal funding of local and state governments
- H** equal voting rights for African Americans
- J** equal representation in the Senate and House

29 During the mid-1800s Chinese immigrants to the United States were an important source of labor for which of the following industries?

- A** Railroad construction
- B** Steel manufacturing
- C** Oil production
- D** Ship construction

Use the map and your knowledge of social studies to answer the following question.

Three Gorges Dam Project

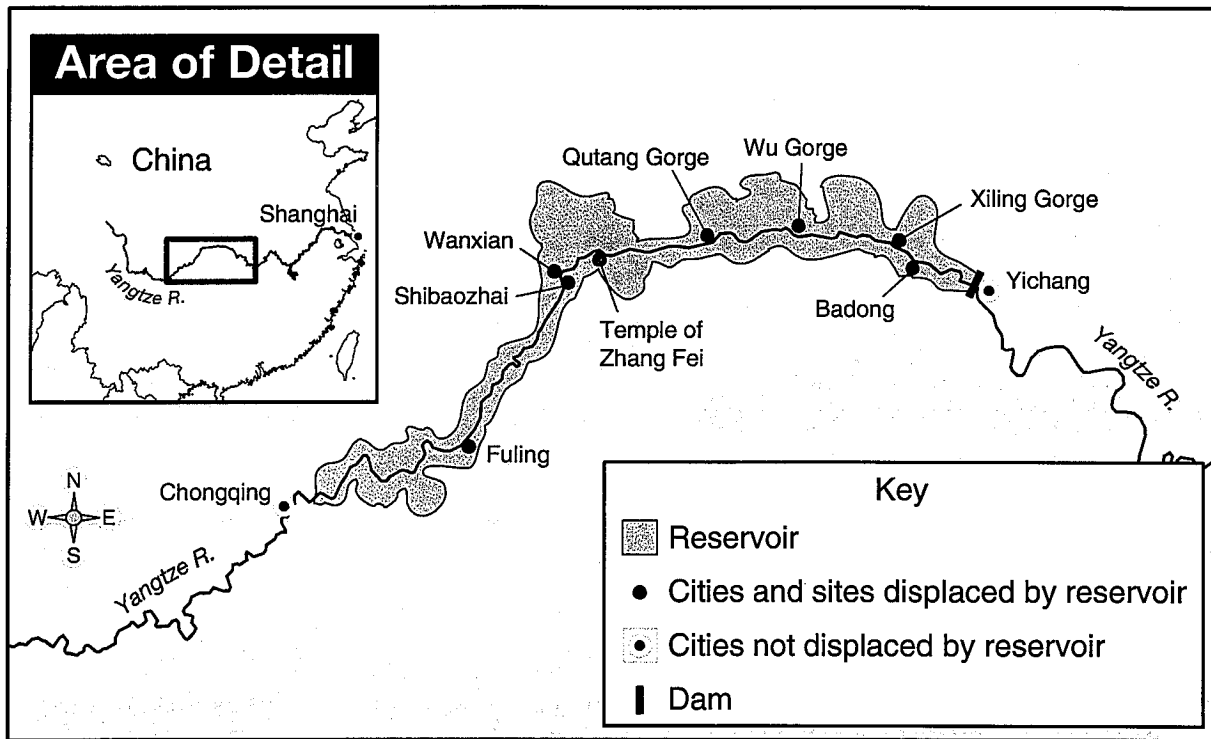

- 30 The most negative effect of the Three Gorges Dam, illustrated above, is the —
- F decrease in international investment
 - G loss of construction jobs
 - H blocking of navigable rivers
 - J removal of people's homes

31 By setting aside millions of acres of land under public domain during the early 1900s, Theodore Roosevelt promoted which of the following concepts?

- A Political reform
- B Conservationism
- C Collective bargaining
- D Agribusiness

32 U.S. involvement in Korea and Vietnam reflected the U.S. government's policy of preventing the spread of communism after World War II. Which of the following established this U.S. policy?

- F Alliance for Progress
- G *Open Door Notes*
- H Truman Doctrine
- J Patriot Act

Use the excerpt and your knowledge of social studies to answer the following question.

Who, that was not a witness, could imagine that the most violent local prejudices would cease so soon, and that men who came from the different parts of the continent, strongly disposed . . . to despise and quarrel with each other, would instantly become but one patriotic band of brothers. . . .

— *Excerpt from Farewell Orders to the Continental Army, November 2, 1783*

33 As commander of the troops described above, which individual delivered this speech?

- A Ethan Allen
- B John Hancock
- C Benedict Arnold
- D George Washington

Use the map and your knowledge of social studies to answer the following question.

U.S. Population Density, 1850

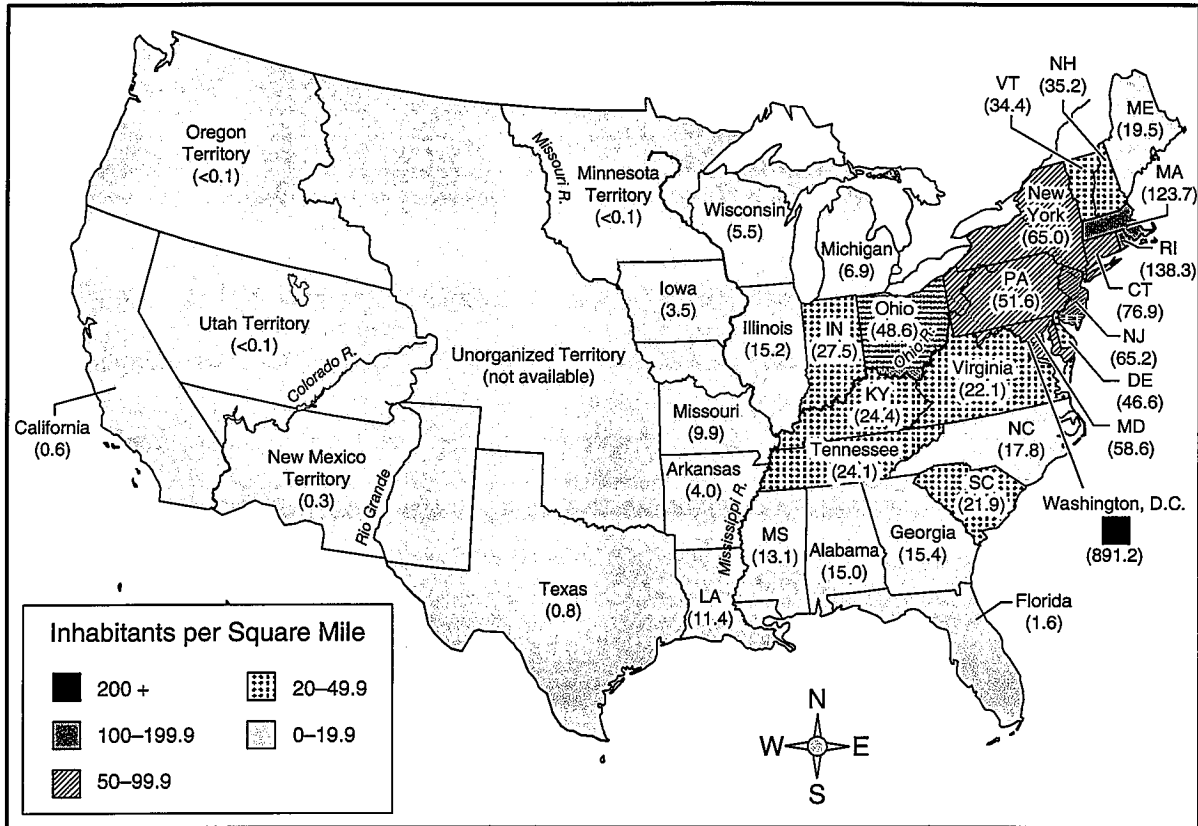

Source: Historical Statistics of the United States

34 According to the information on the map, in 1850 the population density was the greatest —

- F along the Pacific Coast
- G east of the Mississippi River
- H along the Gulf Coast
- J in the areas bordering Mexico

Use the diagram and your knowledge of social studies to answer the following question.

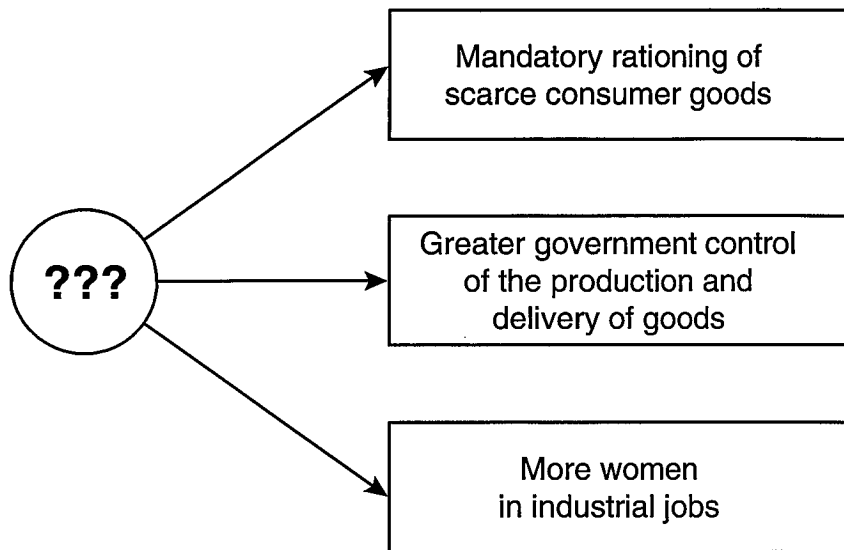

35 What was responsible for the economic conditions shown in the diagram?

- A Cold War
- B New Deal
- C World War II
- D Great Society

36 Which document was written in 1787 and replaced the Articles of Confederation as federal law?

- F** Declaration of Independence
- G** Treaty of Paris
- H** U.S. Constitution
- J** Monroe Doctrine

38 During the 1920s the nationwide prohibition of the manufacture, sale, or transportation of alcohol in the United States contributed to the —

- F** ratification of the women's suffrage amendment
- G** growth of organized crime
- H** end of Progressive reform
- J** demand for stricter immigration policies

Use the excerpt and your knowledge of social studies to answer the following question.

Much has been given us, and much will rightfully be expected from us. We have duties to others and duties to ourselves; and we can shirk neither. We have become a great nation. . . .

— *Excerpt from Theodore Roosevelt's Inaugural Address, March 4, 1905*

37 The excerpt above most likely suggests that the United States —

- A** has moved into a position of world power
- B** needs to impose higher taxes on imported goods
- C** has accepted the role of isolationist nation
- D** needs to concentrate on domestic issues

Use the table and your knowledge of social studies to answer the following question.

Selected U.S. Trade Policies

Fordney-McCumber Tariff	<ul style="list-style-type: none">• High protective tariff• Granted president power to raise rates with approval by Tariff Commission• Made it more difficult for European nations to conduct trade
Smoot-Hawley Tariff	<ul style="list-style-type: none">• High protective tariff• Foreign nations retaliated with high tariffs• U.S. foreign trade decreased
General Agreement on Tariffs and Trade	<ul style="list-style-type: none">• Reduced barriers to international trade• Pledged to reduce tariffs• Led to creation of World Trade Organization
North American Free Trade Agreement	<ul style="list-style-type: none">• Removed most trade barriers between Mexico, Canada, and the United States• Set rules of origin for agricultural products

- 39 Which of the following most likely resulted in economic cooperation between nations on a global level?
- A Fordney-McCumber Tariff
 - B Smoot-Hawley Tariff
 - C General Agreement on Tariffs and Trade
 - D North American Free Trade Agreement

Use the map and your knowledge of social studies to answer the following question.

The Roman Empire, A.D. 106

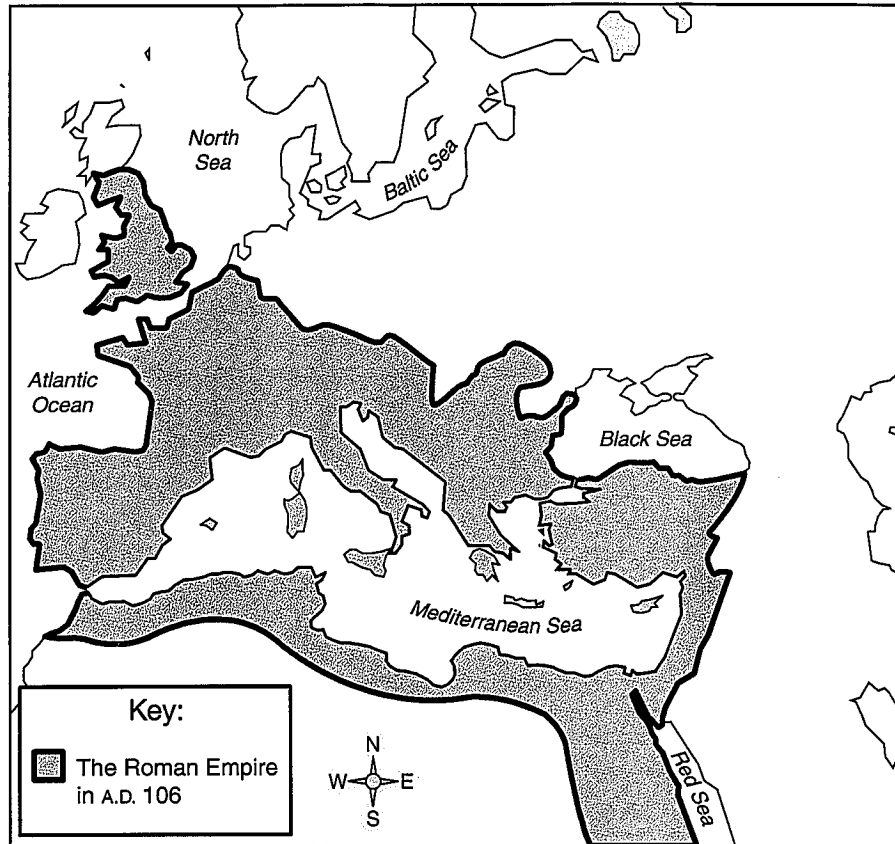

40 Which of the following is the most accurate conclusion based on information on the map?

- F The Romans conquered the territory surrounding the Baltic Sea.
- G By A.D. 106 the Roman Empire extended across three continents.
- H The Roman Empire did not extend beyond the Mediterranean Sea.
- J By A.D. 106 the Romans controlled the entire African continent.

Use the diagram and your knowledge of social studies to answer the following question.

The Development of the Textile Industry

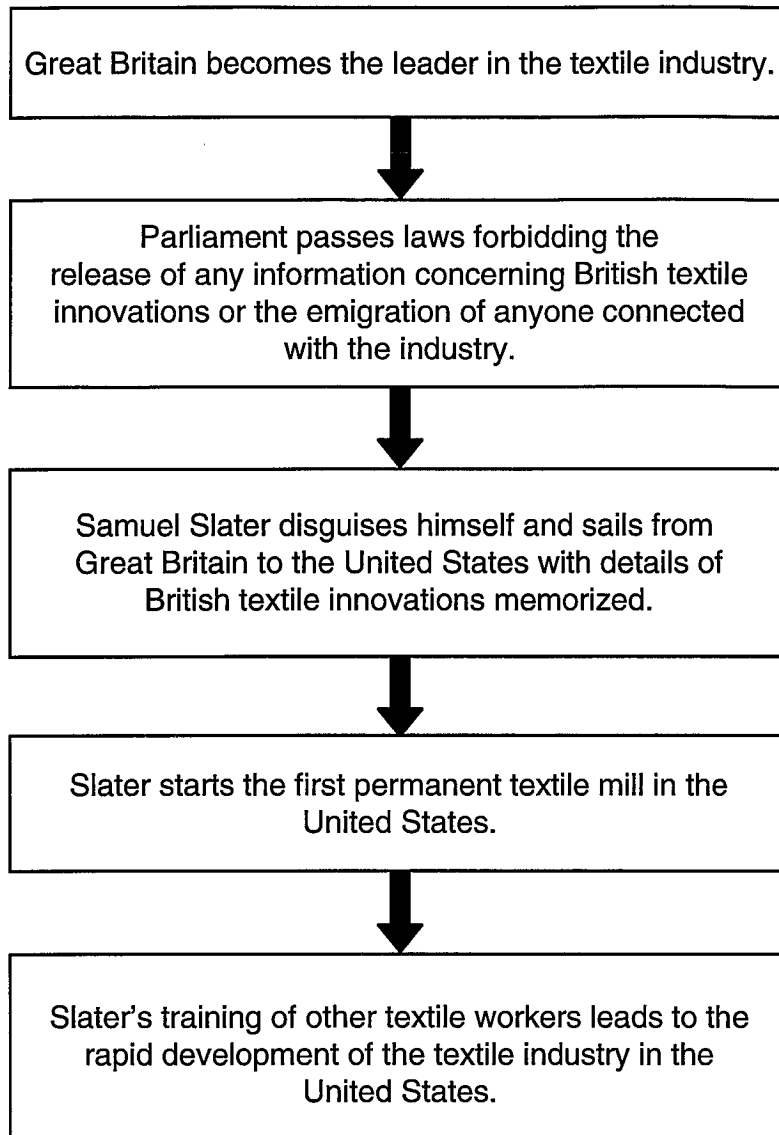

41 Which statement best summarizes the development of the textile industry in the United States?

- A The textile industry in the United States surpassed the British textile industry.
- B Parliament shared the secrets of British textile innovations with foreign competitors.
- C British textile innovations were used to advance the U.S. textile industry.
- D Samuel Slater followed the law that protected the British textile industry.

Use the headline and your knowledge of social studies to answer the following question.



42 The headline above reflects which of the following political concepts?

- F Separation of powers
- G Freedom of the press
- H Popular sovereignty
- J Right to a speedy trial

43 Which of the following principles of U.S. government best characterizes the First Amendment to the U.S. Constitution?

- A Republicanism
- B Individual rights
- C Federalism
- D Popular sovereignty

44 The launch of *Sputnik I* and *Sputnik II* by the Soviet Union in 1957 led the United States to —

- F form an alliance with communist China
- G reduce its defense spending
- H reinstate the military draft
- J accelerate its space program

Use the information in the box and your knowledge of social studies to answer the following question.

Maginot Line

- A series of steel and concrete fortifications built by France after World War I
- Stretched for nearly 150 miles along the border between France and Germany
- Built in response to two German invasions in the previous 50 years

45 It can best be supported from the information above that the French built the structures described above in order to —

- A encourage economic growth
- B increase military security
- C provide jobs for the unemployed
- D enhance national loyalty

Use the table and your knowledge of social studies to answer the following question.

Immigration to the United States, 1880–1919
Selected Points of Origin

	1880–1889	1890–1899	1900–1909	1910–1919
Northern Europe				
United Kingdom	810,900	328,579	469,578	371,878
Scandinavia (Norway, Sweden, Denmark, and Iceland)	761,783	390,729	488,208	238,275
Ireland	764,061	405,710	344,940	166,455
German Empire	1,445,181	579,072	328,722	174,227
Central Europe				
Austria-Hungary	314,787	534,059	2,001,376	1,154,727
Eastern Europe				
Russia	182,698	450,101	1,501,301	1,106,998
Southern Europe				
Italy	276,660	603,761	1,930,475	1,229,916

Source: U.S. Census Bureau

- 46 According to the table above, which is the most accurate statement?
- F Immigration from Italy increased from 1880 to 1909.
 - G Southern European immigrants faced immigration restrictions prior to 1900.
 - H Immigration from Russia decreased from 1880 to 1919.
 - J Northern European immigrants met with hostility prior to 1900.

Use the excerpt and your knowledge of social studies to answer the following question.

Here they are become men: in Europe they were as so many useless plants. . . . They withered, and were mowed down by want, hunger, and war; but now by the power of transplantation, like all other plants they have taken root. . . .

—*Excerpt from Letters from an American Farmer, J. Hector St. John de Crevecoeur, 1782*

- 47 Which of the following does de Crevecoeur suggest happens when people immigrate to the United States?
- A They pay taxes.
 - B They work in factories.
 - C They start families.
 - D They improve their lives.

Use the map and your knowledge of social studies to answer the following question.

Southeast Asia

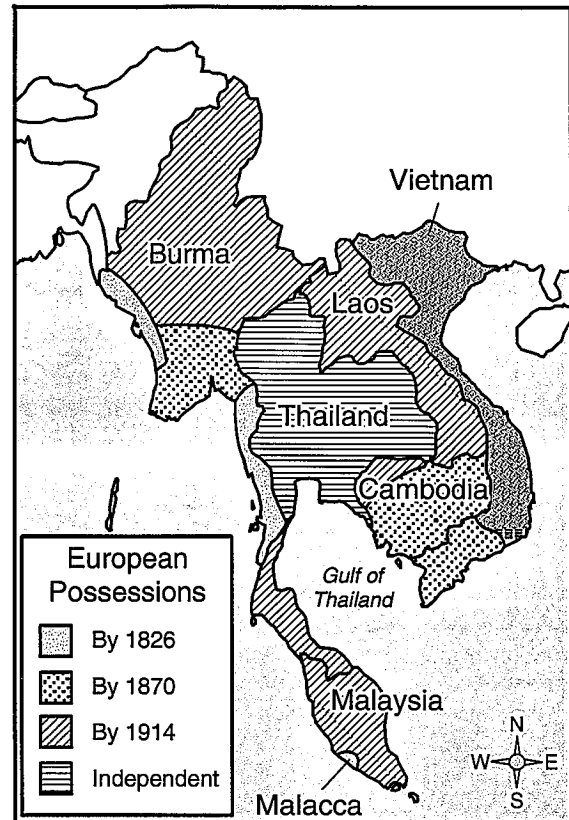

- 48 According to the map, which of the following areas was the earliest to be colonized by Europeans?
- F Laos
 - G Cambodia
 - H Malacca
 - J Malaysia

49 The expansion of America's railroad network in the late 1800s changed the standard of living by —

- A creating employment opportunities for women and children
- B establishing an example for ethical business practices
- C increasing the availability and variety of consumer goods
- D discouraging economic competition with foreign countries

50 The invention of the electric elevator contributed to the growth of cities in the United States by —

- F reducing the need for large industrial complexes
- G making the construction of taller buildings practical
- H leading to federal regulation of all urban construction
- J eliminating the need to build tenement housing

Use the information in the box and your knowledge of social studies to answer the following question.

The Suez Canal

- European ships trading with Asia had to sail around Africa.
- A French company built a waterway to connect the Mediterranean Sea to the Red Sea.
- Referred to as the "crossroads of Europe, Africa, and Asia," the waterway opened in 1869.

51 Like the Panama Canal, the Suez Canal changed economic history because —

- A U.S. restrictions prevented access to most ships
- B the high cost of construction resulted in a worldwide depression
- C goods could get to the consumer faster than before
- D the United States was responsible for its military protection

52 Why was Martin Luther King, Jr., chosen as *Time* magazine's 1963 "Man of the Year"?

- F He supported the unionization of farmworkers.
- G He had become the symbol of the Civil Rights movement.
- H He traveled to India to talk to the followers of Mohandas Gandhi.
- J He became the first African American Supreme Court justice.

Use the diagram and your knowledge of social studies to answer the following question.

Venice, Italy

Venice was originally composed of more than 100 small islands located in a shallow lagoon.

During the barbarian invasions of northern Italy, people sought shelter on the numerous islands in the lagoon.

The early inhabitants built houses on pilings to escape the swampy conditions and constructed canals to provide a method of transportation.

Today there are more than 200 canals that serve as streets and avenues.

- 53 The information given in the diagram above provides a good example of —
- A a people's ability to adapt to the environment
 - B the introduction of innovations to sailing vessels
 - C a government's responsibility to cooperate with industry
 - D the economic development of the fishing industry

Use the information in the box and your knowledge of social studies to answer the following question.

- Invention of the cotton gin
- Use of interchangeable parts
- Introduction of the assembly line

54 The innovations listed above had a direct impact on —

- F reform movements
- G union organization
- H western expansion
- J industrial development

Use the illustration and your knowledge of social studies to answer the following question.

Convention for Women's Suffrage

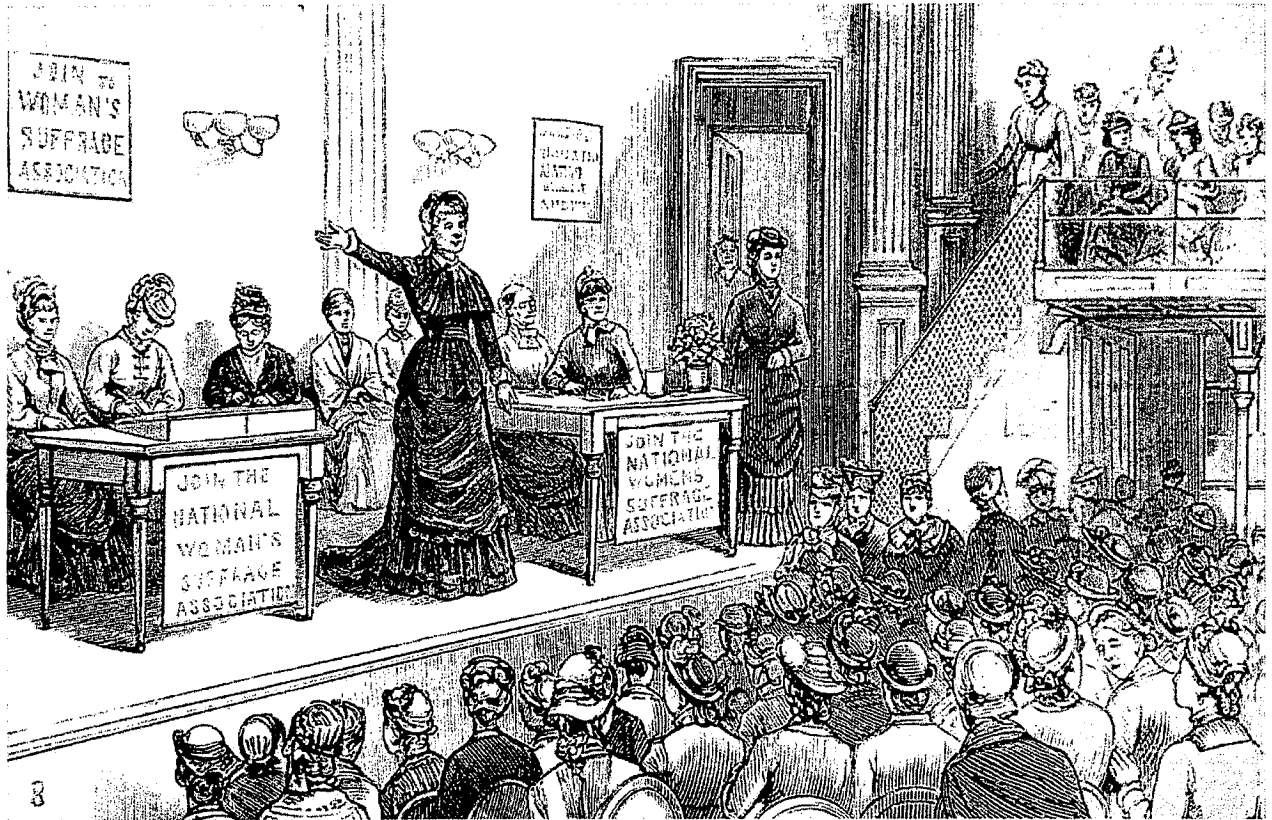

- 55 It can best be concluded from the illustration above that the women's suffrage movement —
- A utilized the protection of free speech to spread its message
 - B employed scare tactics to intimidate the audience
 - C proposed child-labor reform
 - D advocated violence to spread its philosophy

BE SURE YOU HAVE RECORDED ALL OF YOUR ANSWERS
ON THE ANSWER DOCUMENT.





TAKS EXIT LEVEL
JULY 2006



Texas Assessment of Knowledge and Skills - Answer Key

Grade: Exit Level
Subject: ELA
Administration: July 2006

The letter F indicates that the student expectation listed is from the English III TEKS.

Item Number	Correct Answer	Objective Measured	Student Expectations
01	C	01	F.6 (B)
02	F	01	F.7 (F)
03	B	01	F.7 (F)
04	H	01	F.7 (F)
05	D	02	F.11 (C)
06	F	02	F.11 (C)
07	A	02	F.11 (F)
08	J	02	F.10 (B)
09	B	02	F.11 (F)
10	H	03	F.10 (B)
11	B	03	F.12 (A)
12	H	03	F.7 (G)
13	D	01	F.6 (E)
14	J	01	F.7 (F)
15	C	01	F.7 (F)
16	F	01	F.7 (F)
17	C	02	F.11 (C)
18	F	02	F.10 (B)
19	B	03	F.12 (A)
20	F	03	F.12 (A)
21	C	03	F.7 (G)
22	F	03	F.7 (E)
23	B	02	F.11 (A)
24	H	03	F.7 (G)
25	D	03	F.12 (A)
26	F	03	F.20 (B)
27	C	03	F.19 (C)
28	F	03	F.19 (B)
29	*	02	F.10 (B)
30	*	03	F.10 (B)
31	*	03	F.10 (B)
32	G	06	F.3 (B)
33	B	06	F.2 (C)
34	J	06	F.3 (B)
35	B	06	F.3 (B)
36	J	06	F.2 (C)
37	C	06	F.3 (B)
38	H	06	F.2 (C)
39	C	06	F.3 (A)
40	G	06	F.2 (C)
41	A	06	F.3 (B)
42	H	06	F.3 (A)
43	B	06	F.3 (B)
44	G	06	F.2 (C)
45	C	06	F.3 (A)
46	H	06	F.3 (A)
47	B	06	F.3 (A)
48	J	06	F.3 (B)
49	D	06	F.3 (D)
50	F	06	F.3 (C)
51	D	06	F.2 (C)
Writing Task	*	04 & 05	F.1 (B)

*A scoring guide is used to determine the scores for the written composition and short-answer items.



Texas Assessment of Knowledge and Skills - Answer Key

Grade: Exit Level
Subject: Mathematics
Administration: July 2006

The letter **A** indicates that the student expectation listed is from the Algebra I TEKS.

The letter **G** indicates that the student expectation listed is from the Geometry TEKS.

Item Number	Correct Answer	Objective Measured	Student Expectations
01	A	05	A.D1 (C)
02	G	09	8.11 (B)
03	B	10	8.14 (A)
04	J	07	G.D1 (B)
05	C	02	A.B4 (A)
06	G	08	G.E1 (A)
07	D	06	G.E3 (A)
08	H	02	A.B2 (C)
09	B	04	A.C4 (A)
10	H	08	G.F1 (C)
11	B	07	G.D2 (C)
12	F	05	A.D1 (B)
13	C	10	8.16 (B)
14	G	01	A.B1 (C)
15	D	03	A.C2 (A)
16	F	09	8.12 (C)
17	C	01	A.B1 (D)
18	G	08	G.E1 (A)
19	A	06	G.C1 (B)
20	F	03	A.C2 (E)
21	Z	04	A.C4 (B)
22	H	10	8.16 (B)
23	A	05	A.D3 (A)
24	J	06	G.B4 (A)
25	C	01	A.B1 (E)
26	F	02	A.B3 (A)
27	B	06	G.C1 (C)
28	H	10	8.14 (C)
29	B	08	G.E1 (C)
30	J	04	A.C3 (B)
31	A	06	G.C1 (B)
32	H	08	G.F1 (D)
33	D	03	A.C2 (C)
34	G	10	8.14 (A)
35	D	09	8.3 (B)
36	H	02	A.B2 (A)
37	B	01	A.B1 (C)
38	J	10	8.14 (C)
39	A	08	G.F1 (B)
40	G	07	G.D2 (B)
41	A	09	8.3 (B)
42	G	03	A.C2 (G)
43	B	07	G.D2 (A)
44	F	02	A.B4 (B)
45	C	08	G.E1 (B)
46	J	06	G.C1 (C)
47	B	07	G.E2 (D)
48	G	10	8.14 (C)
49	D	09	8.13 (B)
50	G	10	8.16 (B)
51	B	05	A.D1 (D)
52	J	04	A.C3 (A)
53	A	05	A.D2 (B)
54	G	06	G.C1 (A)
55	C	10	8.14 (C)
56	G	01	A.B1 (B)
57	D	07	G.D2 (C)
58	J	03	A.C2 (B)
59	A	04	A.C3 (C)
60	G	07	G.D1 (C)



Texas Assessment of Knowledge and Skills - Answer Key

Grade: Exit Level
Subject: Science
Administration: July 2006

The letter **B** indicates that the student expectation listed is from the Biology I TEKS.

The letter **I** indicates that the student expectation listed is from the Integrated Physics and Chemistry TEKS.

Item Number	Correct Answer	Objective Measured	Student Expectations
01	C	01	I.3 (A)
02	J	03	B.4 (D)
03	D	01	B.2 (A)
04	F	03	B.7 (B)
05	D	01	B.2 (A)
06	F	01	B.2 (D)
07	B	05	I.6 (A)
08	J	05	I.4 (B)
09	C	05	I.6 (D)
10	G	02	B.6 (C)
11	B	05	I.5 (B)
12	H	04	I.8 (C)
13	B	05	I.6 (B)
14	H	04	I.8 (A)
15	D	01	I.3 (B)
16	G	01	B.2 (A)
17	D	04	I.7 (D)
18	G	01	B.1 (A)
19	D	05	I.6 (D)
20	630	05	I.4 (B)
21	A	01	B.2 (D)
22	J	01	I.3 (A)
23	A	02	B.4 (B)
24	G	05	I.4 (A)
25	A	02	B.10 (A)
26	F	01	B.2 (A)
27	D	04	I.8 (C)
28	G	05	I.6 (D)
29	D	04	I.9 (D)
30	G	01	B.2 (C)
31	D	04	I.7 (D)
32	G	02	B.6 (C)
33	D	01	B.2 (D)
34	F	04	I.7 (D)
35	C	02	B.10 (B)
36	G	03	B.4 (D)
37	A	01	B.2 (C)
38	G	04	I.7 (A)
39	B	05	I.5 (B)
40	F	01	B.2 (B)
41	D	02	B.6 (B)
42	J	03	B.9 (D)
43	B	04	I.7 (A)
44	F	01	B.2 (D)
45	B	02	B.4 (B)
46	H	03	B.12 (B)
47	D	03	B.4 (C)
48	J	04	I.7 (A)
49	B	01	B.2 (A)
50	G	04	I.7 (D)
51	C	03	B.13 (A)
52	F	02	B.6 (C)
53	D	05	I.4 (A)
54	G	03	B.7 (A)
55	D	01	B.2 (A)



Texas Assessment of Knowledge and Skills - Answer Key

Grade: Exit Level
Subject: Social Studies
Administration: July 2006

The letter **W** indicates that the student expectation listed is from the World History TEKS.

The letter **G** indicates that the student expectation listed is from the World Geography TEKS.

The letter **H** indicates that the student expectation listed is from the U.S. History Since Reconstruction TEKS.

Item Number	Correct Answer	Objective Measured	Student Expectations
01	C	05	H.24 (F)
02	H	05	H.24 (A)
03	D	03	H.2 (B)
04	F	05	G.21 (C)
05	D	02	H.9 (A)
06	F	04	8.20 (A)
07	D	03	H.21 (A)
08	F	04	8.20 (A)
09	B	03	H.13 (C)
10	H	01	H.5 (B)
11	D	03	H.22 (A)
12	H	03	H.13 (A)
13	B	05	W.26 (C)
14	F	02	H.11 (A)
15	B	01	H.1 (C)
16	J	04	H.7 (C)
17	C	02	H.9 (A)
18	H	03	H.13 (B)
19	A	01	H.1 (B)
20	H	01	H.6 (B)
21	B	03	G.5 (B)
22	H	04	8.3 (A)
23	D	01	8.1 (C)
24	G	04	8.16 (A)
25	D	01	H.6 (D)
26	G	05	H.24 (C)
27	D	01	H.3 (B)
28	F	04	H.4 (A)
29	A	02	H.10 (B)
30	J	05	G.8 (B)
31	B	03	H.4 (B)
32	H	01	H.6 (E)
33	D	01	8.4 (B)
34	G	02	H.8 (B)
35	C	03	H.14 (A)
36	H	01	8.1 (C)
37	A	01	H.3 (A)
38	G	01	H.5 (A)
39	C	03	H.14 (E)
40	G	05	W.26 (C)
41	C	02	G.1 (B)
42	G	04	8.22 (B)
43	B	04	8.16 (D)
44	J	01	H.6 (F)
45	B	05	G.8 (B)
46	F	02	H.8 (B)
47	D	05	H.24 (B)
48	H	05	G.21 (C)
49	C	03	H.23 (A)
50	G	03	H.22 (A)
51	C	02	H.9 (A)
52	G	03	H.7 (B)
53	A	05	G.8 (B)
54	J	02	W.23 (A)
55	A	04	8.22 (B)